



PRODUCT CATALOG

2024-2025



GAS BOILERS | WATER HEATERS | COMBI FURNACES

For more information contact your local NTI representative or visit ntiboilers.com

TABLE OF CONTENTS

CONDENSING GAS BOILERS

- 08** Boiler Selection Guide
- 10** TFTN Series
- 14** FTVN Series II
- 16** TRX Series II
- 18** NTI Compass
- 20** Lx Series
- 22** FTG Series

WATER HEATING

- 25** Lx-WH Series
- 27** Trin & Stor Tanks
- 30** S20W High-Output Combi System

INTEGRATED SYSTEMS

- 33** GF150 Combi Furnace

ACCESSORIES

- 36** Boiler and Tank Parts

WARRANTIES

- 38** High-Efficiency Gas Product Limited Warranty
- 40** Indirect Water Heater and Storage Tank Limited Lifetime Warranty

ABOUT **NTI BOILERS**

We're NTI.
The partner you can trust.

We offer unmatched product quality and service. Our engineers strive to set new standards for high efficiency gas boilers, water heaters and combi furnaces.

NTI is an industry leader and we have been committed to providing smart climate solutions and personal customer support since we were founded in 1967. Today our head office and manufacturing facility are located on the stunning Drury Cove in Saint John, NB, a location chosen to delight those who visit us.

We are not only pioneers in the development of the most advanced and efficient central heating systems, but at NTI we listen to our customers and use their feedback to guide our innovation. Our knowledgeable, accessible friendly staff are here to support every customer to maximize product performance... and just make their jobs easier.

Acknowledged as a leader in research and product development, NTI manufactures its top-quality, hydronic products in accordance with the most advanced guidelines and industry codes. Its products are developed using state-of-the-art design and testing techniques.

The on-site laboratory and training facilities ensure to maintain NTI commitment to enduring quality, product development and contractor support.



Our customer service team, extended warranty programs and unique training opportunities underline our commitment to you. With NTI, you get quality, North American-made products and unparalleled support.

When you buy an NTI product, peace of mind is included.

The NTI brand is the center of excellence for manufacturing and development for heating products, of the Ariston Group in North America.

All over the world, Ariston is synonymous with comfort, energy efficiency and respect for the environment, thanks to its high efficiency products, its plants in compliance with the most advanced production standards and excellent pre- and after-sales customer support services. Our global vision with 9 operating companies, in 40 countries, and 28 production facilities, 29 centres of competences and R&D in 15 countries from.

The Group has now a leadership position in the global thermal comfort market for domestic, commercial and industrial spaces. The Group counts 10,769 employees and, in 2023, it reached 3,092 billion Euros in sales, and produced 8.5 million product.

We love to hear your feedback! Contact us at

info@ntiboilers.com

to provide your opinion on our products and services

NTI^{net} REMOTE CONNECTIVITY

Wi-Fi on board for remote assistance and monitoring

Every unit is equipped with embedded WI-FI connectivity so our products can easily communicate with NTI NET Pro, the webplatform for remote assistance to make service easier.

With NTI NET Pro service, companies can monitor all their boilers with the NTI NET program.

Step into a new era of customer care with our cutting-edge remote diagnostic system and 24/7 monitoring, placing us closer to our customers than ever before. No more waiting for problems to arise – our system detects maintenance needs and abnormalities, saving

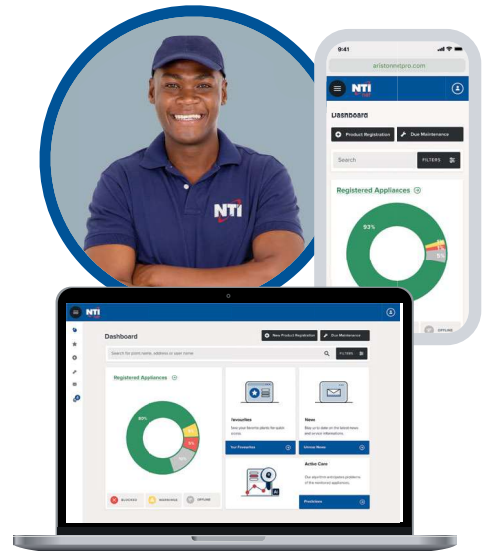

time and preventing heating disruptions. Instant push notifications alert our service teams to any issues, allowing for quick fixes right from afar. We proactively review boiler operations and schedule service appointments, ensuring smooth functioning at all times.

Plus, with the ability to adjust settings remotely, we guarantee optimal performance with ease. Our intuitive NTI NET web platform brings all these tools together, offering convenient access to maintenance and service scheduling from anywhere. Accessible from anywhere, it's not just a smart operational choice but also a great business opportunity.



Your route to efficiency
and customer satisfaction.

CONDENSING GAS BOILERS

**THE RIGHT SOLUTION
FOR ANY APPLICATION**

CONDENSING GAS BOILERS

FOR ANY NEED

The NTI gas boilers lineup is the widest in the market, allowing our customers to find the right solution for any installation.

Our offering has been designed with our customers at the core of what we do. We are constantly using feedback from the field to guide our innovation. Over the years we have implemented continuous improvements and new features with one goal: your satisfaction.

Here are few of the features that make our boilers unique and allow us to make a difference when it comes to the installation and maintenance of our products:

Top condensing technology

As one of the pioneers to introduce high efficiency condensing boilers to North America, NTI designs only best in class products.

We use only high quality stainless steel heat exchangers to provide efficiency and reliability at the same time.

**TOP
EFFICIENCY
PERFORMANCES**

Legendary ignition

We are known for our quality ignition. All NTI boilers are equipped with an external high-energy spark transformer to ensure proper ignition, each and every time.



120V convenience outlet

Cost effective convenience. Selected NTI products come with a built-in 120V convenience outlet. You can use it to power a condensate pump or just to charge your phone!

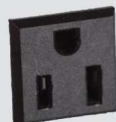

Multi-unit cascade function

Connect up to 8 boilers with our integrated cascading function to easily meet even the most demanding installations. No optional devices required.

**INTEGRATED
CASCADE
FUNCTION**

Universal vent connections with embedded test port

Our vent connections include a combustion analyzer test port and can accommodate PVC/CPVC, PP and stainless steel pipes without the need for any adapters.



Outdoor reset sensor included

We make sure you have the right components you need to install our boilers. Our outdoor reset sensor is high quality and field-tested (and is included!).



Note: Not all features available on all products, please consult the model specifications.

TFTN



From 85 to 850 MBH

Supreme Fire Tube:
Residential and light commercial boiler,
Touch screen and Wi-Fi enabled.

FTVN Series II



From 85 to 199 MBH
Combi available 110, 150,
199 MBH

Fire Tube, made simple:
High-efficiency, wall-hung fire tube boiler,
and Wi-Fi enabled.

TRX Series II



From 85 to 199 MBH
Combi available 110, 150,
199 MBH

Superior water tube design;
Improved water tube boiler
design and Wi-Fi enabled.

NTI COMPASS



From 85 to 199 MBH
Combi available 110, 150,
199 MBH

Superior Fire Tube; Left or right
hand reversible connections and
Wi-Fi enabled.

LX



From 150 to 800 MBH

Floor standing (models 400 and
larger) and wall mount (models 150-
300) Water Tube; For light to most
commercial applications, the Lx is the
ideal option for high-power heating.

FTG



From 1200 to 2,400
MBH

Floor-Standing Fire Tube:
For heavy commercial applications
delivering maximum efficiency and
reliable heat.

CONDENSING GAS BOILER SELECTION

This boiler selection guide is meant to provide a quick overview of the NTI wide product range. For detailed information about a specific product, please see relevant product brochures and manuals or visit ntiboilers.com

	HEAT ONLY		
	TFTN	FTVN SERIES II	TRX SERIES II
Max Power Input	85 - 850 MBH	85 - 199 MBH	85 - 199 MBH
Turn Down ratio	up to 10:1	10:1	up to 10:1
Efficiency	up to 96% AFUE	up to 96% AFUE	up to 96% AFUE
Heat Exchanger	Stainless Steel Fire Tube	Stainless Steel Fire Tube	Stainless Steel Water Tube
Combustion air intake	Sealed Cabinet	Sealed Cabinet	Sealed Cabinet
Internal piping material	Stainless Steel	Copper	Copper
Water connections	Top and Bottom (for 85-399MBH only)	Bottom	Bottom
Cascade installation	√ (up to 8)	√ (up to 8)	√ (up to 8)
Propane conversion kit	√	√	√
Outdoor reset	√	√	√
Integrated Low Water Cut-off	√		
Integrated primary Loop pump		√	√
Integrated indirect tank circulation pump		√	√
Dedicated indirect tank connections		√	√
High Voltage Spark Ignition	√	√	√
Integrated 120 V condensate pump receptacle	√		
Warranty	Parts	5y*	5y
	Heat Exchanger	Limited Lifetime*	Limited Lifetime*
Ideal for	High end boiler for residential or light commercial applications	Cost effective and reliable space heating residential applications	Cost effective and reliable space heating residential applications

* Residential application only. Please see warranty section for more details.

NTI COMPASS	Lx	FTG	FTVN SERIES II COMBI	TRX SERIES II COMBI
85 - 199 MBH	150 - 800 MBH	1200 - 2350 MBH	110 - 199 MBH	DHW: 114 - 197 MBH Heating: 106 - 197 MBH
10:1	up to 8:1	up to 10:1	10:1	up to 11:1
Up to 96% AFUE	93.5% AFUE / 94% T.E.	96% T.E.	95% AFUE	95% AFUE
Stainless Steel Fire Tube	Stainless Steel Water Tube	Stainless Steel Fire Tube	Stainless Steel Fire Tube	Stainless Steel Water Tube
Sealed Cabinet	Direct connection	Sealed Cabinet	Sealed Cabinet	Sealed Cabinet
Copper	N/A	N/A	Copper	Copper
Left or Right	Left	Rear	Bottom	Bottom
√ (up to 8)	√ (up to 8)	√ (up to 8)	√ (up to 8)	√ (up to 8)
√	√ (except Lx600 - Lx800)	√	√	√
√	√	√	√	√
	Lx500-800 has safety water flow switch	√		
√			√	√
√			N/A	N/A
√			N/A	N/A
√	√	√	√	√
		√		
5y	5y*	2y	5y	5y
Limited Lifetime*	10 years*	10 years	Limited Lifetime	Limited Lifetime
Cost effective and reliable space heating residential applications	Light to heavy commercial applications	Fire Tube boiler for commercial applications of any kind	Cost effective and reliable fire tube combination residential boiler	Cost effective and reliable combination residential boiler

* Residential application only. Please see warranty section for more details.

TFTN SERIES



Delivering state-of-the-art functionality and flexibility

TFTN residential and light commercial boilers deliver unprecedented functionality with a proprietary control that is intuitive and easy to program. With Wi-Fi capability, TFTN also feature NTI Net that allows remote diagnostic system and 24/7 monitoring. Using the same legendary reliability, quality construction and state-of-the-art technology that were at the heart of the TFTN's predecessor, the TFT, trust the TFTN to deliver.

The TFTN features an impressive, **high-quality 7" color Touch screen** and robust new control designed for improved precision and efficiency with easy-to-read graphics. It features NTI's newly designed **EZ SetUp Wizard**, designed with input from contractors, to deliver intuitive, and quick set up and performance.



Available in eleven sizes ranging from: **85 MBH to 850 MBH**

Up to **96% AFUE**

Main Features:

- EZ Setup Wizard control
- Large color Touch screen
- NTI Net for 24/7 remote access and monitoring
- Built-in low water cutoff
- Built-in 3-zone control (valves or pumps); can expand to six heating zones with N-LINK
- Top and bottom plumbing connections for easy installation (not applicable on 500-800MBH units)



Field gas convertible
NG or LP

Onboard
Wi-Fi

Cascade
installation
up to **8**

High-energy
spark igni-
tion

120V
Convenience
Outlet



SCAN HERE!
For more info
about the TFTN!

Dimensions - Wall Mount

FRONT

DIM	85-110	150-199	285	340-399
a	34 1/4"	34 1/4"	34 1/4"	36 1/2"
b	3 1/4"	3 1/4"	3 1/4"	5 3/8"
c	19 7/8"	19 7/8"	21 3/8"	25 1/4"
d	42 3/4"	42 3/4"	53 5/8"	57 5/8"

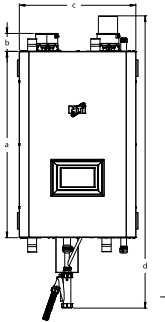

TOP

DIM	85-110	150-199	285	340-399
e	17 1/4"	18 3/4"	18 7/8"	21 1/4"
f	3 7/8"	3 3/4"	5"	4 1/2"
g	N/A	N/A	7 1/2"	N/A
h	6"	6 3/8"	5 1/8"	3 3/8"
i	3 1/2"	3 3/4"	3 3/4"	6 1/2"
j	N/A	N/A	13 3/8"	14"
k	N/A	N/A	7 1/2"	4 3/8"

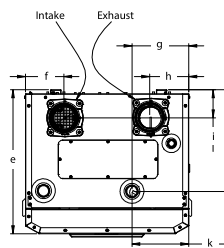

BOTTOM

DIM	85-110	150-199	285	340-399
l	2 3/4"	2 3/4"	2 3/8"	5 5/8"
m	4 5/8"	4 5/8"	7"	8 7/8"
n	5"	6 1/5"	13 1/4"	15 1/2"
o	11 3/4"	12 3/4"	13 7/8"	14 3/4"
p	6 3/8"	7 1/4"	7"	10 7/8"
q	2 1/2"	2 3/8"	2 1/4"	2 5/8"
r	N/A	N/A	5 3/8"	4 1/8"
s	9 7/8"	9 7/8"	8 3/4"	13 7/8"

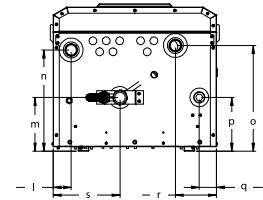

Specifications - Wall Mount

	TFTN085	TFTN110	TFTN150	TFTN199	TFTN285	TFTN340	TFTN399
CSA Input Modulation (MBH) ¹	8.5 - 85	11 - 110	15 - 150	19.9 - 199	28.5 - 285	39.9 - 340	39.9 - 399
Heating Capacity (MBH) ^{1,2}	79	101	138	184	263	324	380
Net AHRI Rating, Water (MBH) ^{1,2}	69	88	120	160	229	282	330
AFUE (%) ²	96	95	95	95	95	95.4	95.4
Water Connections, NPT (in.)	1-1/4 (M)	1-1/4 (M)	1-1/4 (M)	1-1/4 (M)	1-1/4 (M)	1-1/2 (M)	1-1/2 (M)
Gas Connection, NPT (in.)	3/4 (M)	3/4 (M)	3/4 (M)	3/4 (M)	3/4 (M)	3/4 (M)	3/4 (M)
Vent/Air-inlet Pipe Diameter (in.) ³	2 or 3	2 or 3	2 or 3	2 or 3	3	4	4
Cabinet Height (in.)	34-1/8	34-1/8	34-1/8	34-1/8	34-1/8	36-1/2	36-1/2
Cabinet Width (in.)	19-7/8	19-7/8	19-7/8	19-7/8	21-3/8	25-1/4	25-1/4
Cabinet Depth (in.)	17-1/4	17-1/4	18-3/4	18-3/4	18-3/8	18-7/8	21-1/4
Approx. Boiler Weight with Water (lbs)	107	107	122	140	180	250	250
Approx. Boiler Water Content (Gallons)	1.4	1.4	2	2.8	4.9	7.1	6.4
Electrical Rating	120V / 1Ph / 60Hz / less than 12A						

- Listed Input and Output ratings are at minimum vent lengths at an altitude of 0-2000 ft. Numbers will be lower with longer venting and/or altitudes greater than 2000 ft.
- Ratings based on standard test procedures prescribed by the U.S. Department of Energy; certified by AHRI. Efficiency listed for models TFTN340 and TFTN399 represents Thermal Efficiency (AFUE is not applicable).
- TFTN units require a special venting system, use only vent materials and methods detailed in the installation manual.

Floor Mount - 4 sizes from 500 to 850 MBH

Includes all the features of our wall-mount sizes, but with differences in specifications and performance, connections and switches:

- 97 - 97.7% Thermal Efficiency
- 160 psi MAWP
- 10:1 turndown ratio
- All connections are in the back, including the exhaust and air intake
- Isolation relays for pumps and gas valve/dry contact
- CSD-1 ready with high and low gas pressure switches
- Leveling legs
- Only 28" wide: fits through a standard door

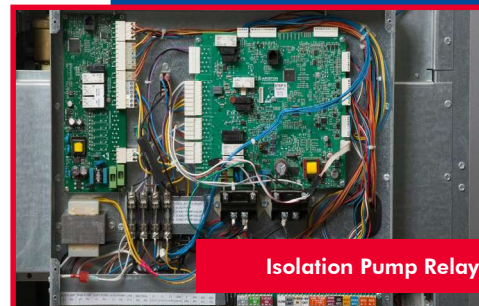

TFTN - Floor Mount



TFTN - Wall Mount

Specifications - Floor Mount

	TFTN500	TFTN600	TFTN725	TFTN850
CSA Input Modulation (MBH) ⁴	50 - 500	60 - 600	72.5 - 725	85 - 850
DOE Heating Capacity (MBH) ^{4,2}	489	585	705	825
Net AHRI Rating, Water (MBH) ^{4,2}	425	509	613	717
Combustion Efficiency (%) ²	98	97.8	97.7	97.6
Thermal Efficiency (%) ²	97.7	97.5	97.2	97
Water Connections, NPT (in.)	2 (M)	2 (M)	2.5 (M)	2.5 (M)
Gas Connection, NPT (in.)	1 (M)	1 (M)	1-1/4 (M)	1-1/4 (M)
Exhaust Connection (in.) ³	4	4	6	6
Air Intake Connection (in.)	4	4	4	4
Cabinet Height (in.)	62-1/2			
Cabinet Width (in.)	28-1/4			
Cabinet Depth (in.)	27-5/8			
Approx. Boiler weight with Water (lbs.)	575	575	685	690
Approx. Boiler Water Content (Gallons)	12.5	12.5	17.5	16.5
Electrical Rating	120V / 1Ph / 60Hz / less than 12A			

- Ratings based on standard test procedures prescribed by the U.S. Department of Energy; certified by AHRI.
- TFTN units require a special venting system, use only vent materials and methods detailed in the installation manual.
- Ratings based on standard test procedures prescribed by the U.S. Department of Energy; certified by AHRI.

Accessories:

- TFTN Series tool box
- Low profile vent terminal
- Concentric vent terminal
- Common venting for TFTN 340/399
- System water temperature sensor
- Room sensors
- N-Link zone control
- BMS Gateway Kit
- Optional floor stands for wall mount models

LIMITED LIFETIME / **5y**
PRIMARY HEAT EXCHANGER PARTS
WARRANTY

Residential applications up to 399. See warranty section for more details.

FTVN SERIES II

| Fire Tube Boilers Made Simple

The FTVN is a high-efficiency, wall-hung boiler equipped with a **vertical fire tube heat exchanger** made of industry proven 439 stainless steel. NTI's user-friendly programmable display features NTI Net connectivity and onboard Wi-Fi. With easy-to-access components, **simple installation, set up and maintenance**, and its unique design the FTVN enables simpler plumbing layouts that **keep costs well under control**.

The FTVN features a powerful high efficiency ECM pump, to quietly circulate water through the boiler and boiler primary loop, or boiler and indirect water heater loop – AN EXTERNAL DHW PUMP IS NOT REQUIRED.

The FTVN has been designed with service in mind. The components are each easily removable, and the space within the cabinet has been maximized so that your hard working hands have space to work. The swing down control box also enhances serviceability, making all major components easily accessible.



We've relaunched our FTVN models with a **new** and advanced user interface for quick and easy installation and maintenance.

Faster setup, troubleshooting, and upkeep for streamlined operations and fewer hassles.

Available in:
85 to 199 MBH

Up to 96% AFUE
10:1 Modulation

Main Features:

- *Advanced User Interface with Easy Setup Wizard*
- *Simpler Wiring with Improved Junction Box*
- *NTI Net for Wi-Fi and Remote Connectivity*
- *Integrated ECM Primary Pump*
- *Combi and Heat Only Versions Available*
- *Built-in 2-zone control; can expand to five heating zones with N-LINK*



Field gas convertible
NG or LP

Onboard
Wi-Fi

Cascade
installation
up to **8**

High-energy
spark ignition



SCAN HERE!
For more info
about the FTVN!

Dimensions

A	Central Heating Outlet
B	DHW Outlet (combi or indirect)
C	Gas Inlet
D	DHW Inlet (combi only)
E	Central Heating Inlet
F	Condensate Drain

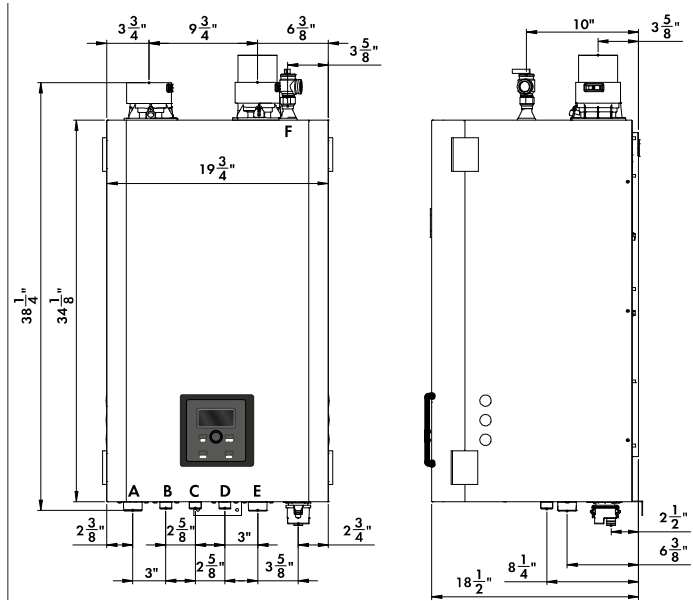

Specifications

	FTVN085	FTVN110	FTVN150	FTVN199	FTVN110C	FTVN150C	FTVN199C
Input Heating MBH	8.5-85	11-110	15-150	19.9-199	11 - 110	15 - 150	19.9 - 199
Input (DHW Combi)							
AFUE	96%	95%	95%	95%	95%	95%	95%
Heating Capacity (MBH)	79	101	138	184	101	138	184
Net AHRI Rating (MBH)	69	88	120	160	88	120	160
Combi Water Flow at 77° FT Rise	N/A				2.6 GPM	3.6 GPM	4.8 GPM
Weight (lbs)	107	107	124	145	108	125	146
Water Content (Gallons)	2.1	2.1	3.0	3.7	2.2	3.1	3.8
Water Connections (Heating)	1-1/4" NPT-M						
Water Connections (DHW)	3/4" NPT-M						
2" Inlet & Exhaust Distance	100' max						
3" Inlet & Exhaust Distance	150' max						
Gas Connection All Models	3/4" Male						

Accessories:

- FTVN Series tool box
- Floor stand
- Low profile vent terminal
- Concentric vent terminal
- Tempering valve
- System water temperature sensor
- N-Link zone control
- Room sensors
- Primary/secondary manifold
- S20W and Plus Kit



See warranty section for more details.

TRX SERIES II



We've relaunched our TRX models with a **new** and advanced user interface for quick and easy installation and maintenance.

Faster setup, troubleshooting, and upkeep for streamlined operations and fewer hassles.



SCAN HERE!
For more info about the TRX!

| The next level of water tube boilers

The TRX is the **advanced NTI platform and the new industry standard** for Combi applications. The improved water flow design, NTI Net connectivity, and onboard Wi-Fi, makes the TRX the best choice available on the market.

The TRX boiler (central heating) is capable of providing water temps for both space heating and DHW with the use of an external indirect water heater. It provides an internal pump, and diverter valve, eliminating the need for an additional indirect pump and fitting. All internal components utilize bayonet quick connectors, making it one of the fastest products in the market to install.

Components can be efficiently serviced. Swing down control box greatly enhances serviceability, making all major components easily accessible.

Available in three sizes:
085 - 199 MBH

Up to 96% AFUE

Main Features:

- *Advanced User Interface with Easy Setup Wizard*
- *Simpler Wiring with Improved Junction Box*
- *NTI Net for Wi-Fi and Remote Connectivity*
- *Integrated ECM Primary Pump*
- *Combi and Heat Only Versions Available*



Field gas convertible
NG or LP

Onboard
Wi-Fi

Cascade
installation
up to **8**

High-energy
spark ignition

Dimensions

A	Central Heating Outlet
B	Domestic Hot Water Outlet
C	3/4" Gas Inlet
D	Domestic Hot Water Inlet
E	Central Heating Inlet
F	Condensate Drain
G	Electrical Connections

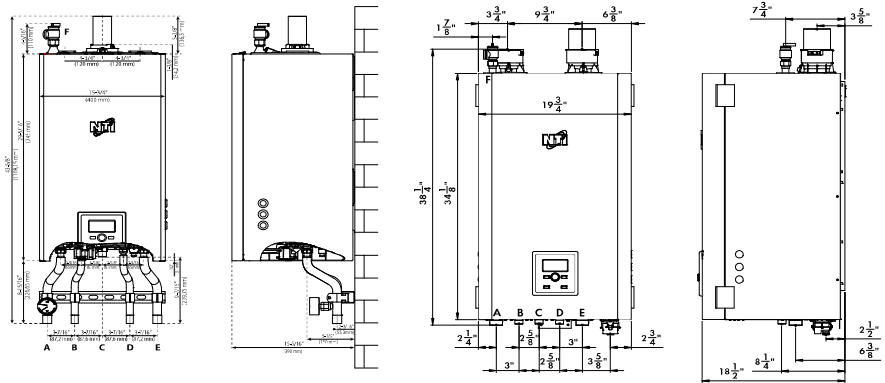

TRX085, 110, 110C, 120 & 150C

TRX150, 199, 199C

Specifications

	TRX085	TRX120	TRX150	TRX199	TRX110C	TRX150C	TRX199C
Input Heating	9.4-85	13.2-120	15-150	19.7-197	11.2 - 106	13.2 - 120	19.7 - 197
Input DHW					11.2 - 114	13.2 - 150	
AFUE	96%	95%	95%	95%	95.5%	95%	95%
Heating capacity (MBH)	79	111	139	184	98	111	184
Net AHRI Rating (MBH)	69	97	121	160	85	97	160
DHW Flow Rate at 77°F T Rise (Combi)	N/A				2.7 GPM	3.5	4.8
Weight (lbs)	88	89	115	130	91	93	135
Water Content	1.1	1.2	2	2.7	1.1	1.2	2.7
Gas Connection	3/4 in. NPT Male						
Water Connections (Heating)	1 in. sweat	1 1/4 in. NPT Male		1 in. sweat		1 1/4 in. NPT Male	
Water Connection (DHW)	3/4 in. sweat	3/4 in. NPT Male		3/4 in. sweat		3/4 in. NPT Male	
2" Inlet & Exhaust Distance	100' max						
3" Inlet & Exhaust Distance	150' max						
Gas Connection All Models	3/4" Male						

Accessories:

- TRX Series toolbox
- Floor stand
- Low profile vent terminal
- Concentric vent terminal
- Tempering valve
- System water temperature sensor
- N-Link zone control
- Room sensors
- Primary/secondary manifold
- S20W and Plus Kit

LIMITED LIFETIME / **5y**
PRIMARY HEAT EXCHANGER PARTS

WARRANTY

See warranty section for more details.



NTI COMPASS



| Choose your own direction

The NTI Compass is a high-efficiency, floor mounted boiler equipped with a **vertical fire tube heat exchanger** made of industry proven 439 stainless steel. NTI's user-friendly programmable display features NTI Net connectivity and onboard Wi-Fi. With easy-to-access components, **simple installation, set up and maintenance**, and its unique design the NTI Compass enables simpler plumbing layouts that **keep costs well under control**.

The NTI Compass features a powerful high efficiency ECM pump, to quietly circulate water through the boiler and boiler primary loop, or boiler and indirect water heater loop – AN EXTERNAL DHW PUMP IS NOT REQUIRED. Built-in primary/secondary piping makes sure the job's done right. If the system already has primary/secondary piping, just close the internal valve and use the system piping. A true time saver!

The NTI Compass has been designed with service in mind. The components are each easily removable, and the space within the cabinet has been maximized so that your hard working hands have space to work. The swing down control box also enhances serviceability, making all major components easily accessible.

The **NEW** NTI Compass is ideal for replacing cast iron or floor mount condensing boilers. All plumbing connections (CH, DHW, gas, condensate drain) are independently reversible from side to side. No matter what your piping needs are, we've got you covered.

Available in:
85 to 199 MBH

Up to 96% AFUE
10:1 Modulation

Main Features:

- ECM Pump
- Wi-Fi
- Primary/Secondary Piping
- Left or right reversible connections
- Advanced User Interface with Easy Setup Wizard
- Combi and Heat Only Versions Available
- Built-in 2-zone control; can expand to five heating zones with N-LINK



Low NOx

Field gas convertible
NG or LP

Onboard Wi-Fi

Cascade installation up to 8

High-energy spark ignition



SCAN HERE!

For more info about the NTI Compass!

Dimensions

A	Central Heating Supply
B	Supply to Indirect Water Heater; *DHW Out
C	Gas Inlet
D	Return from Indirect Water Heater; *DHW In
E	Central Heating Return
F	Condensate Drain
PRV	Pressure Relief Valve
NOTE 1	Combi = 8-3/4" System = 5-5/8"
NOTE 2	NC085-110=11" NC150-199 = 10-1/4"
NOTE 3	NC085-110= 6" NC150-199 = 6-3/8"

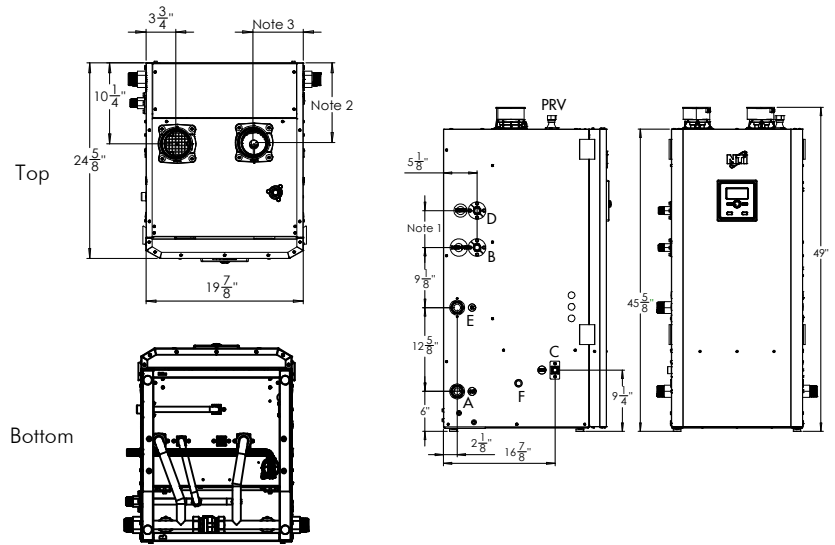

Specifications

	NC085	NC110	NC150	NC199	NC110C	NC150C	NC199C
Input Heating MBH	8.5-85	11-110	15-150	19.9-199	11 - 110	15 - 150	19.9 - 199
Input (DHW Combi)							
AFUE	96%	95%	95%	95%	95%	95%	95%
Heating Capacity (MBH)	79	101	138	184	101	138	184
Net AHRI Rating (MBH)	69	88	120	160	88	120	160
Combi Water Flow at 77° FT Rise	N/A				2.6 GPM	3.6 GPM	4.8 GPM
Weight (lbs)	176	176	192	209	178	195	212
Water Content (Gallons)	2.6	2.6	3.5	4.2	2.7	3.6	4.3
Water Connections (Heating)	1-1/4" NPT-M						
Water Connections (DHW)	3/4" NPT-M						
2" Inlet & Exhaust Distance	100' max						
3" Inlet & Exhaust Distance	150' max						
Gas Connection All Models	3/4" Male						

Accessories:

- NTI Compass Series tool box
- Low profile vent terminal
- Concentric vent terminal
- Tempering valve
- System water temperature sensor
- N-Link zone control
- Room sensors

LIMITED LIFETIME / **5y**
PRIMARY HEAT EXCHANGER PARTS
WARRANTY

See warranty section for more details.

LX SERIES

When you need more power we've got you covered

For light to heavy commercial applications, the Lx is the ideal option, with its **high power stainless steel heat exchanger**. The Lx Series boilers are designed for floor standing installation and can be also mounted wall-hung up to 399 MBH.

Easily accessible components make it service and maintenance friendly.

Cascade management and other outstanding programming features can be easily controlled by the intuitive touch screen display.

Available in six sizes ranging from: **150 MBH to 800 MBH**

Up to 94% Thermal Efficiency

Main Features:

- Touch screen intuitive display
- Wall hung kit included for Lx150-400
- High power sizes up to 800 MPH
- Easy access to the display and internal components
- Advanced cascade settings
- Vents in stainless steel, PVC, CPVC or Polypropylene. (Only directly compatible with PVC.CPVC) Check with local jurisdiction.



Field gas convertible
NG or LP
for most models

Outdoor reset

Cascade installation
up to **8**

High-energy spark ignition



SCAN HERE!
For more info about the LX!

Dimensions

Lx300-400

DIM	300	400
a	21 1/2"	24"
b	10 3/4"	16 1/2"
c	7"	9 1/2"

* Please refer to Lx Series Brochure for dimension of Lx150-200 and Lx500-800

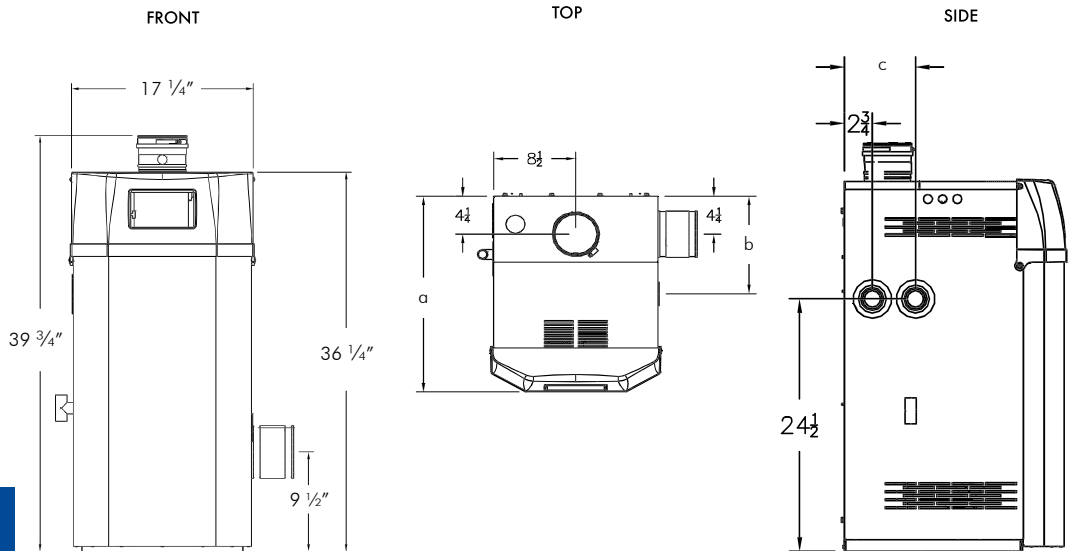

Specifications*

		Lx150	Lx200	Lx300	Lx400	Lx500	Lx600	Lx800
Input Power	Natural Gas	25 - 150 MBH	25 - 199 MBH	55 - 275 MBH	75 - 399 MBH	100 - 500 MBH	120 - 600 MBH	160 - 800 MBH
	Propane	LP max 145 MBH					N/A	N/A
AFUE		93.5%	93.5%	93.7%	94% Thermal Efficiency			
Heating capacity		136 MBH	181 MBH	251 MBH	375 MBH	470 MBH	564 MBH	752 MBH
Net AHRI Rating		118 MBH	157 MBH	218 MBH	326 MBH	409 MBH	490 MBH	654 MBH
Installation type		Indoor Floor Standing (Wall Hung kit included)				Indoor Floor Standing		
Weight		100 lb	125 lb	180 lb	225 lb	320 lb	380 lb	475 lb
Gas connection		1/2 in NPT female	1/2 in NPT female	1/2 in NPT female	3/4 in NPT female	3/4 in NPT female	1 in NPT male	
Water connections		1 in NPT female	1 in NPT female	1 1/4 in NPT female	1 1/4 in NPT female	2 in NPT female		
Air Inlet		NG 3 in (max 105 ft)	3 in (max 105 ft)	4 in (max 100 ft)				6 in (max 100 ft)
Flue		LP 3 in (max 50 ft)	3 in (max 105 ft)	4 in (max 100 ft)				6 in (max 100 ft)

*Lx700 also available. Please refer to Lx Series Brochure for specifications

Accessories:

- Lx Series tool box
- Low profile vent terminal
- Concentric vent terminal
- System water temperature sensor
- Protonode BACnet Gateway
- Air Filter Kit (500-800 models)

LIMITED LIFETIME / **5y**
PRIMARY HEAT EXCHANGER PARTS

WARRANTY

This warranty pertains to most of this product. For more details see the full warranty section.

FTG SERIES

All the power you need for any commercial applications

The FTG is a **stainless steel high efficiency fire tube commercial boiler** that ranges from 800 MBH to 2,350 MBH.

The FTG features a dynamic **multiple heat exchanger design**, with single blower, gas valve and burner. The **user-friendly touch screen display** and **advanced programmable features** make it the ideal choice for dependable and highly demanding commercial applications.

The FTG Series has been designed to provide a reliable source of heat at the maximum energy efficiency levels, without compromises.



Available in six sizes ranging from: **800 MBH to 2,400 MBH**

Up to **96%** Thermal Efficiency

Main Features:

- Touch screen intuitive display
- High performance fire tube stainless steel heat exchanger
- Integrated low water cut-off
- Integrated combustion air filter
- CSD-1 compliant
- Advanced cascade settings
- Sealed cabinet
- Vents in stainless steel, PVC, CPVC or Polypropylene. Check with local jurisdiction.



Field gas convertible
NG or LP

Outdoor reset

Cascade installation up to **8**

High-energy spark ignition

120V Convenience Outlet



SCAN HERE!
For more info about the FTG!

Dimensions

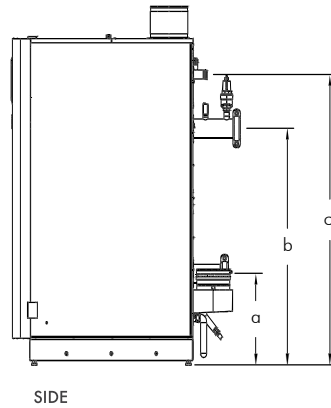
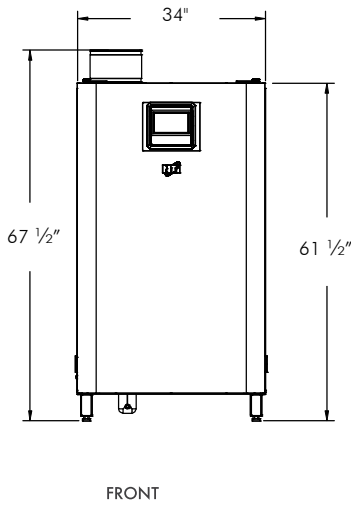

DIM	600-800	1200	1400	2000	2200-2400
a	17 1/4"	67"	67"	67 1/2"	67 1/2"
b	44 1/2"	44 1/4"	44 1/4"	44 3/4"	44 3/4"
c	54 1/2"	54 1/4"	54 1/2"	53 1/2"	53 1/2"
d	29 1/4"	44 1/4"	44 1/4"	60 1/4"	60 1/4"

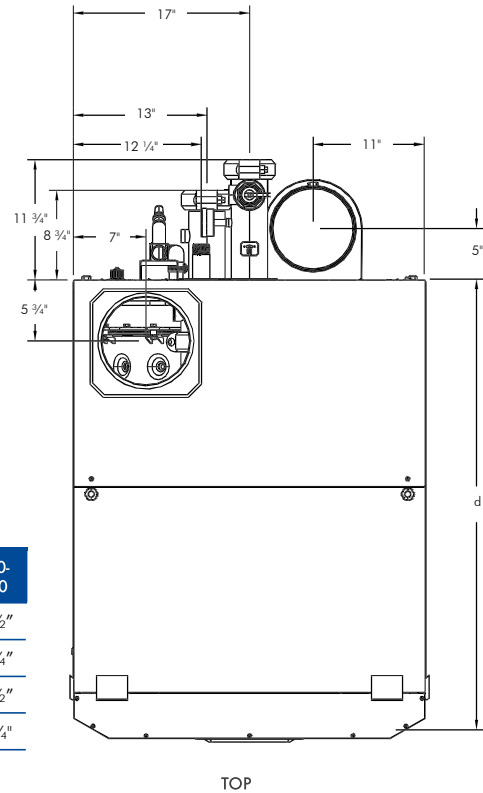

Specifications*

		FTG800	FTG1200	FTG1400	FTG2000	FTG2200	FTG2400
Input Power	Natural Gas	80 - 800 MBH	120 - 1,200 MBH	140 - 1,400 MBH	235 - 2,000 MBH	235 - 2,200 MBH	235 - 2,350 MBH
	Propane						
Thermal Efficiency		95%	96.1%	96%	96%	95.6%	95.2%
Heating capacity		760 MBH	1,153 MBH	1,344 MBH	1,920 MBH	2,103 MBH	2,237 MBH
Net AHRI Rating		660 MBH	1,003 MBH	1,169 MBH	1,670 MBH	1,829 MBH	1,945 MBH
Installation type		Indoor Floor Standing					
Weight		780 lb	1,210 lb			1,710 lb	
Gas connection		1 in NPT female	1 1/4 in NPT female		1 1/2 in NPT male		
Water conn.	Inlet	3 in groove joint					
	Outlet	2 in groove joint	3 in groove joint				
Air Inlet		6 in (max 150 ft)			8 in (max 150 ft)		
Flue		6 in (max 150 ft)			8 in (max 150 ft)		

* FTG600 also available. Please refer to FTG Series Brochure for specifications

Accessories:

- System water temperature sensor
- BACnet gateway



See warranty section for more details.



WATER HEATING

**ABUNDANT HOT WATER
FOR ANY APPLICATION**

LX-WH SERIES

Gas condensing volume water heater for commercial use

The LX-WH combines quality with unmatched efficiency while providing a tremendous output capacity. The **high power stainless steel heat exchanger** is easy to clean and install. The **touch screen display is user-friendly**, and the LX-WH offers **advanced programming features**.

Available in seven sizes ranging from: **199 MBH to 800 MBH**

96%
Thermal Efficiency

Main Features:

- Touch screen intuitive display
- Floor or wall-mount options
- Ideal coupling with Trin&Stor Storage tanks
- High power sizes up to 800 MBH
- Easy access to the display and internal components
- Advanced cascade settings



Field gas convertible
NG or LP
for most models

Cascade installation
up to **8**

High-energy
spark ignition



SCAN HERE!
For more info
about the LX-WH!



Dimensions

DIM	300	400
a	21 1/2"	24"
b	10 1/2"	16 1/2"
c	7"	9 1/2"

* Please refer to LxWH Series Brochure for dimension of Lx200WH and Lx500-800WH

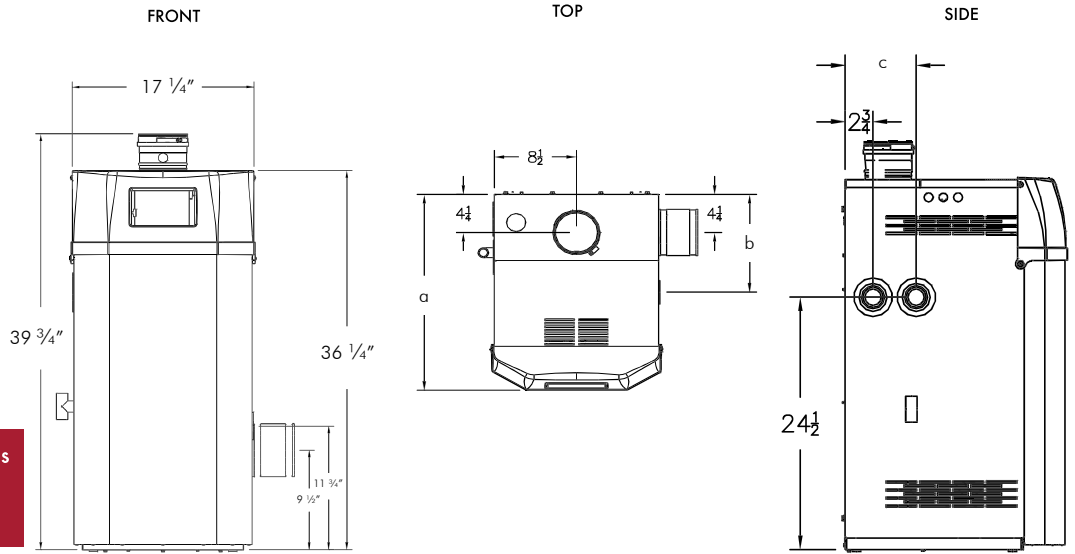

Specifications*

		Lx200WH	Lx300WH	Lx400WH	Lx500WH	Lx600WH	Lx800WH
Input Power	Natural Gas	25 - 199 MBH	55 - 275 MBH	75 - 399 MBH	100 - 500 MBH	120 - 600 MBH	160 - 800 MBH
	Propane					N/A	N/A
GPH at 100°F T Rise		229 GPH	317 GPH	460 GPH	576 GPH	691 GPH	922 GPH
Thermal Efficiency		96%					
Installation type		Indoor Floor Standing (Wall Hung kit included)			Indoor Floor Standing		
Weight		125 lb	180 lb	225 lb	320 lb	380 lb	475 lb
Gas connection		1/2 in NPT female	1/2 in NPT female	3/4 in NPT female	3/4 in NPT female	1 in NPT male	
Water connections		1 in NPT female	1 1/4 in NPT female	1 1/4 in NPT female	2 in NPT female		
Air Inlet		3 in (max 105 ft)	4 in (max 100 ft)				6 in (max 100 ft)
Flue		3 in (max 105 ft) 4 in (max 105 ft)	4 in (max 100 ft)				6 in (max 100 ft)

* Lx700WH also available

Accessories:

- Lx-WH Series tool box
- System water temperature sensor

5y / 2y
PRIMARY HEAT EXCHANGER PARTS

WARRANTY

See warranty section for more details.

TRIN & STOR TANKS

S SERIES



Highest quality stainless steel indirect water heaters and storage tanks

The Trin & Stor passivated stainless steel **storage tanks are renowned for maximum resistance to corrosion, which increases their longevity.** Their **high-quality construction and components** make these storage tanks a popular product, and they come in a **wide range of sizes to fit any need.**

Available in two series with sizes ranging from:
40 gallons to 120 gallons

Main Features:

- Pickled and passivated 444 stainless steel construction
- Simple and quick sensor connection
- Lead free
- High accuracy tank sensor
- Widest product range from 40 to 120 gallons
- Highest quality construction

S/S
TANK



SCAN HERE!
For more info
about the TRIN &
STOR!

V SERIES



Dimensions

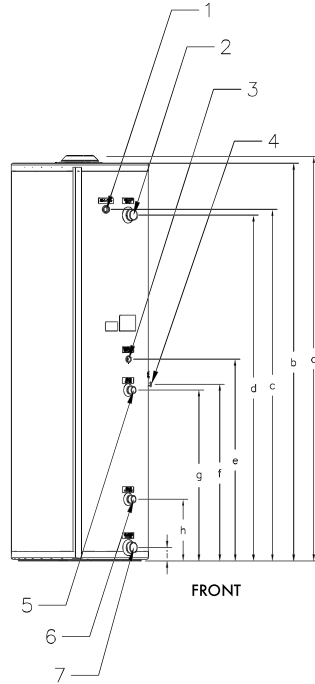
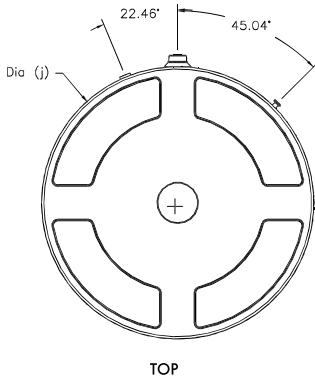

DIM	S40	S50	S65	S80	ST120
a	56"	49"	70 1/2"	70 1/4"	-
b	54 3/4"	47 3/4"	69 1/4"	69"	64 3/4"
c	46 3/4"	39 3/4"	60 1/4"	61"	53 1/2"
d	46 3/4"	39 1/2"	60 1/4"	60"	53 1/4"
e	29"	29 1/2"	32 1/2"	35"	44 1/2"
f	25"	26"	27"	29 1/2"	40 1/2"
g	26"	27"	28"	30 1/2"	41 1/2"
h	9 1/2"	10"	10 1/4"	10 3/4"	12 1/4"
i	2"	2"	2"	2 1/2"	2 1/2"
j	20"	24"	22"	24"	29"
1	3/4" F	3/4" F	3/4" F	3/4" F	3/4" F
2	1" M	1"	1"	1 1/2"	1 1/2"
3	3/4" F	3/4" F	3/4" F	3/4" F	3/4" F
4	1" M	1" M	1" M	1" M	1" M
5	1" M	1" M	1" M	1" M	1" M
6	1" M	1"	1"	1 1/2"	1 1/2"
7	Well	Well	Well	Well	Well

Specifications - S Series

	INDIRECT WATER HEATERS						
	S40	S50	S65	S80	S120	ST80	ST120
Storage capacity	40 gal	53 gal	65 gal	79 gal	119 gal	79 gal	119 gal
Tank material	Stainless Steel						
Coil material	Stainless Steel					N/A	
Insulation	EPS Foam					EPS Foam	
Weight empty	71	90	100	115	157	160	175
Weight filled	485	655	800	995	1,275	1,040	1,293
Continuous recovery	140°F	181 gal	211 gal	275 gal	314 gal	389 gal	N/A
	115°F	287 gal	332 gal	432 gal	495 gal	615 gal	N/A
Boiler output	146 MBH	146 MBH	210 MBH	210 MBH	290 MBH	N/A	N/A
Coil flow rate	6.9 GPM	6.9 GPM	10.4 GPM	10.4 GPM	13.6 GPM	N/A	N/A
Coil pressure drop	0.5 PSI	0.5 PSI	1.5 PSI	1.5 PSI	2.1 PSI	N/A	N/A
Hour 1 recovery	140°F	213 GPH	251 GPH	327 GPH	378 GPH	485 GPH	N/A
	115°F	319 GPH	372 GPH	484 GPH	559 GPH	711 GPH	N/A

Accessories:

- Aquastat



See warranty section for more details.

Dimensions

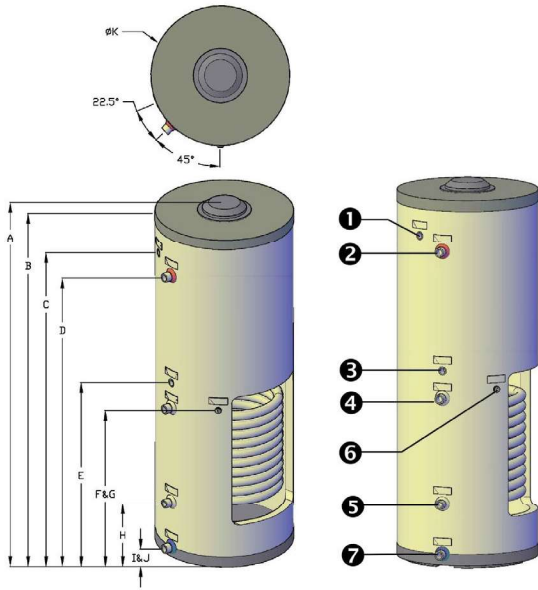

DIM	V40	V50	V65	V80	V120
a	-	-	-	-	-
b	44.9	56.7	54.3	64.2	69.7
c	36.4	48.2	45.1	55	59.8
d	36.4	48.2	45.1	54.6	59.4
e	28.5	32.5	32.9	37.6	35.4
f	25.4	29.3	29.8	34.5	32.2
g	26.4	30.3	30.7	35.5	33.2
h	8.9	8.9	9.3	9.3	10.2
i	3.1	3.1	3	3.3	3.4
j	3.1	3.1	3	3.3	3.4
k	21.8	21.8	24.5	24.5	28.1
1	3/4" F	3/4" F	3/4" F	3/4" F	3/4" F
2	1" M	1" M	1" M	1" M	1" M
3	3/4" F	3/4" F	3/4" F	3/4" F	3/4" F
4	1" M	1" M	1" M	1" M	1" M
5	1" M	1" M	1" M	1" M	1" M
6	Well	Well	Well	Well	Well
	10mm x 160mm	10mm x 160mm	10mm x 160mm	10mm x 160mm	10mm x 160mm
7	1" M	1" M	1" M	1 1/2" M	1 1/2" M

Specifications - V Series

		INDIRECT WATER HEATERS				
		V40	V50	V65	V80	V120
Storage capacity		38 gal	51 gal	64 gal	77 gal	116 gal
Tank Material		Stainless Steel Indirect				
Weight empty		95 lbs	117 lbs	134 lbs	165 lbs	232 lbs
Weight filled ¹		428 lbs	556 lbs	690 lbs	835 lbs	1235 lbs
Continuous recovery ²	140°F	182 GPH	211 GPH	277 GPH	314 GPH	390 GPH
	115°F	287 GPH	333 GPH	433 GPH	492 GPH	616 GPH
Boiler output		160 MBH	180 MBH	240 MBH	300 MBH	350 MBH
Coil flow rate		10 GPM	10 GPM	15 GPM	15 GPM	20 GPM
Coil pressure drop		1.6'	2.0'	3.8'	5.1'	10.0'
Hour 1 recovery ²	140°F	216 gal	251 gal	334 gal	384 gal	489 gal
	115°F	319 gal	373 gal	485 gal	558 gal	717 gal

1. Ensure the location chosen for installation can support the weight of the tank when filled with water.
2. Ratings based on 50°F inlet water temperature and 200°F boiler water outlet temperature.

Accessories:

- Aquastat
- Tank sensor



See warranty section for more details.

S20W HIGH-OUTPUT COMBI SYSTEM

Space saving high-performance wall-mounted indirect water heater

High output is simple when you choose NTI's S20W system: 1. Pair it with one of NTI's heat-only boiler, and 2. **Tie them together with NTI's made-to-measure Plus Kit.**

The S20W is one of our highest performing tanks, with recovery rates that exceed most industry standard 50 and 65 gallon tanks (or indirects). Its stainless steel tank and coil come in a wall-mounted package complete with a metal jacket. **The CFC-free 2" ultra high density EPS insulation ensures low standby losses and each unit comes complete with a thermostatic mixing valve, tank sensor and T&P valve.** A hand hole at the top of the tank allows for inspection and cleaning.



Available in 20 gallons

Pairs with most heat-only NTI boilers

Main Features:

- Pickled and passivated 444 stainless steel construction
- High quality stainless steel tank and coil, type 444
- CFC-free 2" ultra-high density EPS insulation
- Includes thermostatic mixing valve
- Limited lifetime warranty
- Quick connect with Plus Kit 3260173



SCAN HERE!
For more info about the S20W!

Dimensions

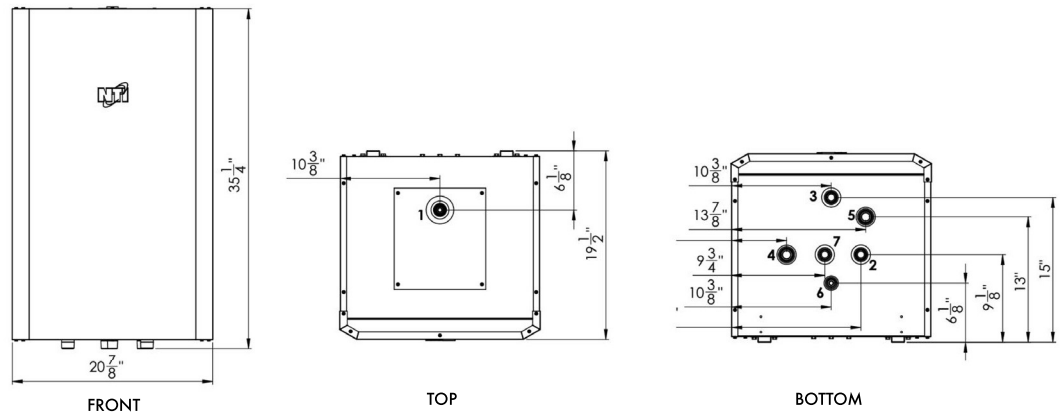

Specifications

Model	Storage Capacity USG (L)	Type	Weight (lbs)		Hour 1 Recovery (Gal @ Outlet Temp)		Boiler Output MBH	Coil Flow Rate (GPM)	Coil Drop (Ft)	Continuous Rate (Gal @ Outlet Temp)	
			Empty	Filled ¹	140° F	115° F				140° F	115° F
S20W	21 (80)	Stainless Steel Indirect	85	260	290 ²	445 ²	232	10	4.5	273 ²	428 ²

1. Ensure the location chosen for the S20W tank is capable of supporting the tank when filled with water.

2. Max. hour 1 recovery based on 50°F inlet water temperature and 200°F boiler supply water temperature.

When matched with the FTVN or TRX the S20W delivers peak performance.

Model	Max. Hour 1 Recovery (US GPH)		Continuous Rate (US GPH)	
	140°F	115°F	140°F	115°F
FTVN085	119	158	102	141
FTVN110	149	200	132	182
FTVN150	197	266	180	249
FTVN199	229	348	212	330
TRX150	197	266	180	249
TRX199	215	345	198	328

Values are with 50°F inlet water.

INTEGRATED SYSTEMS

EMBRACE A NEW
DIMENSION OF COMFORT

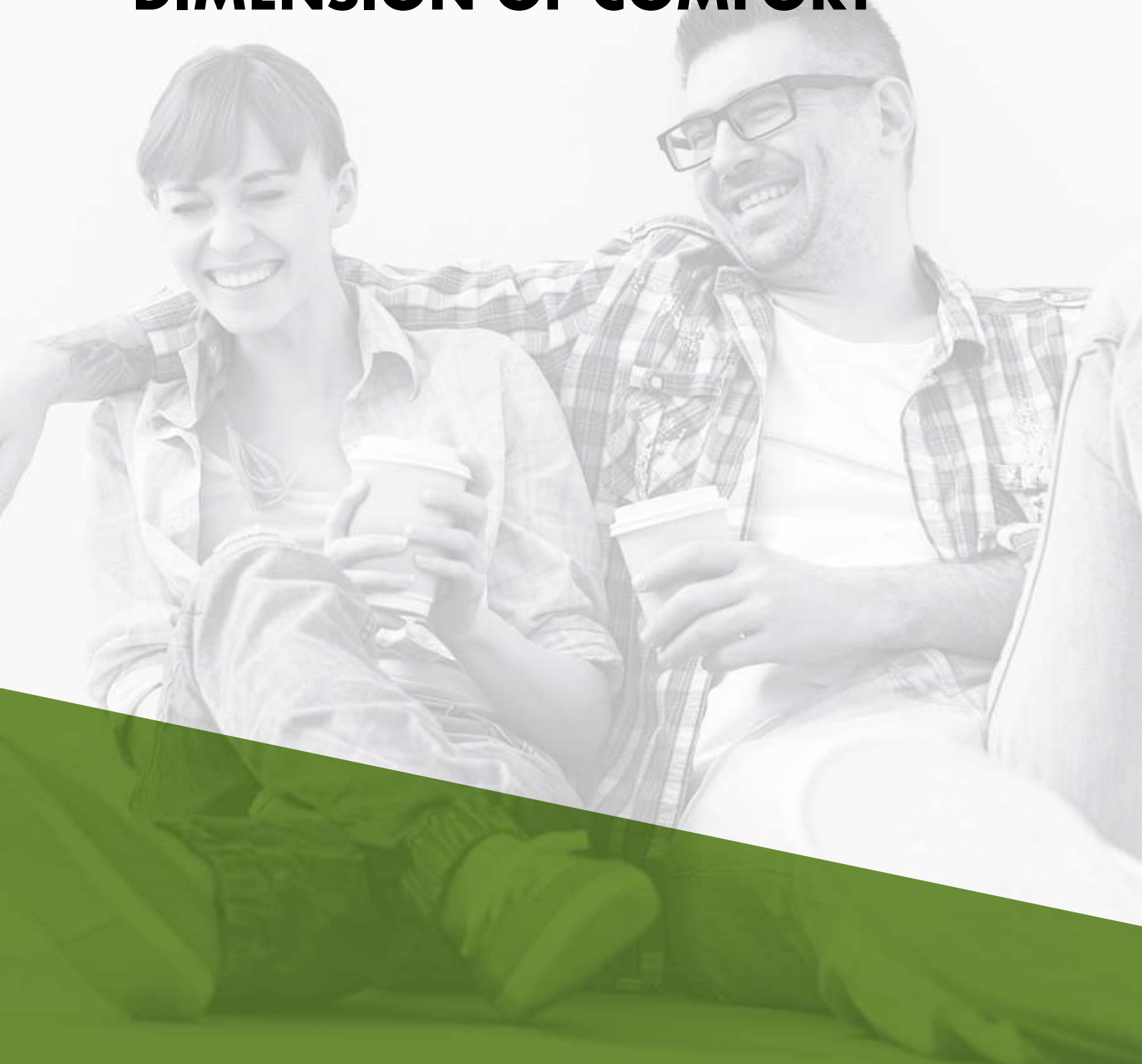

GF150 COMBI FURNACE



Modern Convenience of Hot Water and Forced Air Combined

The GF150 is a merging of our TRX combi boiler with a high efficiency air handler to provide forced-air heating, domestic hot water and hydronic capabilities. It is an **all-in-one solution** for the future of hot water, heating and comfort for your home.

The GF150 is equipped with Green Furnace control technology which features the most advanced components, providing whisper quiet heating performance as well as quick and abundant hot water.



New generation ECM motor and blower for whisper quiet performance.

One size fits all

95% AFUE

Main Features:

- Innovative technology and outstanding performance
- Combined DHW and space heating appliance
- Most advanced DEC Star ECM blower
- High-efficiency combustion system
- Design innovation
- Integrated plumbing
- Integrated Wi-Fi for remote monitoring and troubleshooting
- Left/right connections
- Qualifies for most boiler rebates/incentives



95% AFUE



S/S
HEAT EXCHANGER

ECM
MOTOR

Onboard
Wi-Fi



SCAN HERE!
For more info
about the GF150!

Dimensions

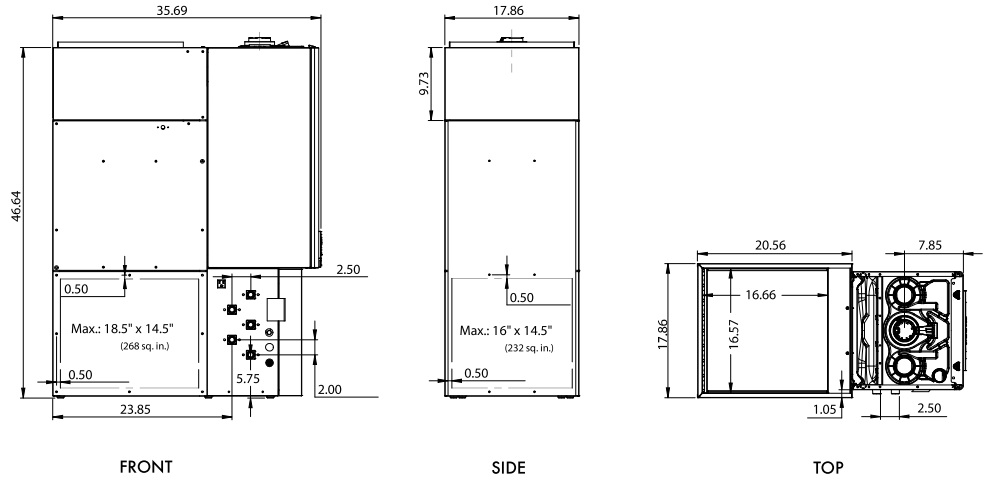

Specifications

	Forced-Air Heating Capacity	13,200 - 80,000 BTU/H	
	Cooling Capacity	Up to 3.0 tons	
Flow Rate (Forced Air)	Heating Ventilation	300 - 1200 CFM (510 - 2040 m ³ /h)	
	Cooling	360 - 1200 CFM (612 - 2040 m ³ /h)	
Connection Sizes	DHW Inlet / Outlet	¾ in. NPT-M	
	CH Supply / Return	¾ in. NPT-M	
	Gas Inlet	¾ in. NPT-M	
Dimensions (W x H x D)		17 7/8 in. x 48 in. x 35 3/4 in. (454 x 1219 x 908 mm)	
Weight		220 lbs. (100 kg.)	
Power Supply		120V AC, 60 Hz, 15 A	
TRX150C*	Energy Efficiency (DOE AFUE)	95%	
	Space Heating Capacity (Hydronic + Forced Air)	13,200 - 120,000 BTU/H (4 - 35 kW)	
	DHW Capacity	13,200 - 150,000 BTU/H (4 - 44 kW)	
	Flow Rate (DHW)	77°F (43°C) Temp Rise	3.6 GPM (14 L/m)
		Minimum	0.5 GPM (2 L/m)
	Water Pressure	DHW Max. Pressure	125 PSI (860 kPa)
		Heat Exchanger MAWP	55 PSI (380 kPa)
	Venting	Length (intake)	2" (0 - 100 ft.) 3" (0 - 150 ft.)
		Length (exhaust)	2" (6 - 100 ft.) 3" (6 - 150 ft.)
Materials		PVC, CPVC, PP, SS	

*The TRX150C is the boiler component of the GF150.



See page 41 for warranty.

ACCESSORIES

BOILER AND TANK PARTS
FOR TOP PERFORMANCE

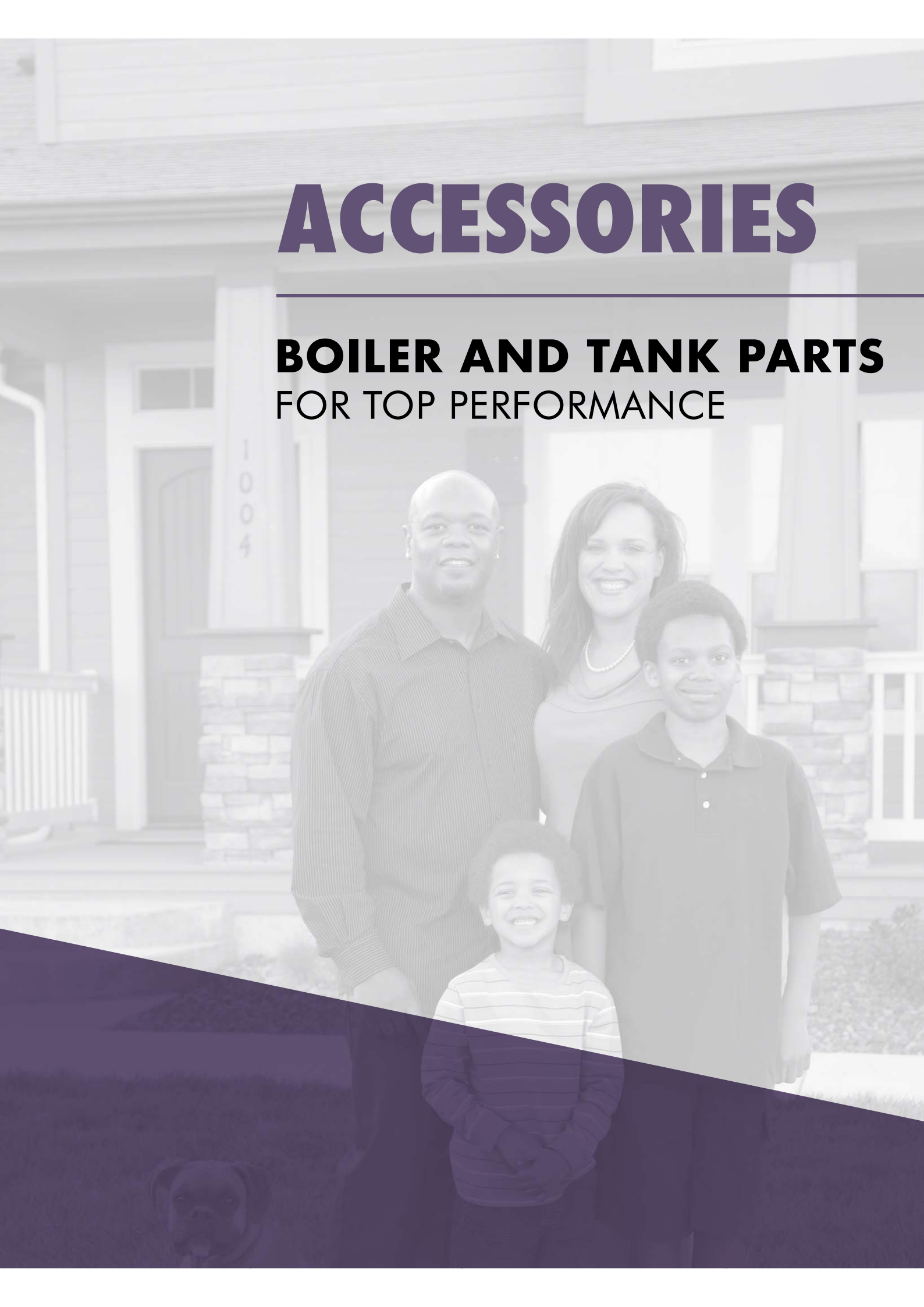

| Accessories

Part Number	Models	Description
87262	All FTVN and TRX 150, 199, 199C	Primary/Secondary Manifold
3319703	TRX 85, 120, 110C, 150C	Primary/Secondary Manifold
3260173	TRX 150, 199, FTVN + S20W	High Output Combi System Plus Kit (includes 87262)
86087	GF200	GF200 Tool Box
86417	FTG	FTG Tool box
86641	Lx	Lx400 Tool Box
86640	Lx	Lx150-300 Tool Box
85224	VMax	VMax Tool Box
86320	TFT	TFT 285-399 Tool Box
86319	TFT	TFT 155-250 Tool Box
86318	TFT	TFT 154-201 Tool Box
86317	TFT	TFT 60-110 Tool Box
87112	FTVN	SK90 Service Kit - FTVN Only
87111	TRX/FTVN	SK90 Service Kit - TRX & FTVN
87110	TRX/FTVN	SK70 Service Kit - TRX & FTVN
87099	TRX/FTVN	Cascade Kits - TRX & FTVN
84947	FTG/Lx	ProtoNode LER Modbus-LonWorks
84946	FTG/Lx	ProtoNode RER Modbus-BACnet/N2
3260186	TFTN	BMS Gateway Kit
86369-1	Lx	High Gas Pressure Switch
84649	Lx	Low Gas Pressure Switch
84632	Trin & Stor	Trin & Stor Tank Sensor
84158	Trin & Stor	Trin & Stor TPI Aquastat
82666/84634	TFT/Lx150-200	3" Concentric Vent Terminal
84358	TFT/Lx300-800	4" Low Profile Vent Terminal
84357	TFT/Lx150-200	3" Low Profile Vent Terminal
84355	TFTLx300-800	4" Concentric Vent Terminal
84093	Lx500-800	Indoor Combustion Air kit
84010	All	System/Pipe Sensor
83450	All	Fernox DS40 Descalar
83449	All	Fernox F3 Cleaner
83448	All	Fernox F1 Protector

WARRANTIES



HIGH-EFFICIENCY GAS PRODUCT LIMITED WARRANTY

Register product purchases at ntiboilers.com.
Retain proof of purchase, installation date and all service records.



To register a product,
SCAN HERE!

A. What Does This Limited Warranty Cover?

This limited warranty covers all parts in your NTI high-efficiency gas product against failure due to defects in materials and workmanship. NTI will replace or, at its sole discretion, repair any defective part. Any replaced part will be warranted for the longer of i) the unexpired portion of the original warranty period or ii) 90 days. Labor and all other costs for the inspection or examination, removal and re-installation of defective parts, and transportation costs for defective or replacement parts, are not covered by this warranty. This warranty applies to all gas units produced on or after Oct. 20, 2021, beginning with serial number 21**102021**38184177, or those with serial number beginning with 326 or 331.

B. How Long Does the Coverage Last?

Item	Coverage Duration		
	Residential	Commercial	Volume Water Heater
Heat Exchanger (i.e., pressure vessel)	Limited Lifetime	10 years from installation date	5 years from installation date
All Other Parts	5 years from installation date	2 years from installation date	2 years from installation date

For the applicable duration as per the above chart, repair, or replacement of a heat exchanger that NTI has found to be defective in material or workmanship that resulted in a leak will be provided by NTI, provided this warranty has not otherwise been voided. For residential products only, for the years following the first 10 years, NTI will provide coverage for a percentage of the material cost of a replacement heat exchanger

according to the following table:

Year from date of installation	Residential % covered by NTI
11th	75%
12th	
13th	50%
14th	
15th and beyond	25%

Coverage will be applied towards the then current retail price of the replacement heat exchanger. NTI uses its published list pricing to represent current retail pricing. In the case where a replacement heat exchanger is no longer available when the warranty claim is made, NTI will offer a replacement product of similar size and characteristics and any applicable warranty coverage will be applied towards the current retail price of aforementioned product. The amount of coverage toward a replacement product is based upon the percentage of the list price of the heat exchanger on the total list price of the replacement product. For example, if a heat exchanger fails in year 13 of an installation and the list price of the heat exchanger represents 25% of the list price of the replacement

product, the warranty coverage applied to the replacement product would be $50\% \times 25\% = 12.5\%$ of the retail list price of the replacement product. **If the installation date cannot be determined, the warranty period will be considered to begin 60 days from the date the product was shipped by NTI, which NTI can determine using the product serial number.**

C. What Does Residential, Commercial and Volume Water Heater mean?

Residential Products – are gas condensing boilers that meet all of the following four conditions:

1. Below 401 MBH
2. Installed in a housing unit of 2 dwellings or less
3. Not used in commercial applications and process water heating
4. Average annual run time not exceeding 2,500 hours

Commercial Products – all gas condensing boilers that do not qualify as residential products.

Volume Water Heater – products that operate in an open-loop domestic hot water system.

D. How Do You Make a Warranty Claim?

If you believe you have a claim under this limited warranty, please contact a local heating or plumbing contractor of your choice, that is familiar with the operation and service requirement of high-efficiency, condensing products. Your contractor will perform a diagnosis to determine the cause of the issue and will work with NTI Boilers Inc. to establish as to whether you may have a claim covered by this warranty. If your contractor advises you that you may have a claim covered by this warranty, then the contractor can choose to file the claim directly with NTI Boilers Inc. on your behalf, or work through a local wholesale distribution partner of NTI Boilers Inc. You must make all parts that are subject to a warranty claim available to your contractor for return to NTI. If you have questions about this process or the status of your claim, you may contact the NTI Technical Services at 1-800-688-2575, or email info@ntiboilers.com. You can also find warranty details and procedures at www.ntiboilers.com. **All warranty requests need to be approved by the NTI Warranty Department prior to a replacement or credit being issued. Warranty requests must be processed through an approved NTI distributor or authorized party; warranty requests from other parties will not be accepted and NTI will advise to redirect these requests through authorized wholesalers or sales representatives.**

E. What Is Not Covered Under This Warranty?

This warranty is valid only for the original owner at the original location. Additionally, this warranty does not cover claims if the failure, malfunction, or unsatisfactory performance of, or damage to, your Product resulted from or is attributable to:

1. Installation not done in accordance with manufacturer's instructions;
2. Components or replacement parts that are not furnished by NTI;
3. The failure to properly size the product for its use;
4. Repairs or replacement of parts required as a result of poor workmanship of the contractor;
5. Repairs or replacement of parts required due to inaccurate diagnosis and troubleshooting by a contractor that did not include the assistance of the NTI Technical Services Department;
6. Failure to inspect and maintain the venting;
7. Water conditions outside of NTI's acceptable parameters, as stated in the NTI product manuals supplied with the product, including, but not limited to, water chemistry, levels of Total Dissolved Solids (TDS) and pH levels, chemical or electrochemical reaction, water impurities, unsuitable water conditions as per system design guidelines, water treatment chemicals;
8. Sediment, magnetite or scale formation on the water side of the pressure vessel;
9. Operation with contaminated combustion air including, but not limited to, air contaminated externally, air impurities, sulfur or sulfuric action or reaction, dust particles, corrosive vapors, oxygen corrosion;
10. Buildup of dirt, dust or other debris inside the combustion chamber;
11. Installing the product in an unsuitable location or continuing use after onset of a malfunction or discovery of a defect;
12. Information supplied by parties other than NTI without consultation and agreement by NTI;

13. Failure to inspect and service the product in accordance with NTI's product manuals;
14. Freezing, accident, fire, flood, or force majeure, power surges or failures, abuse or misuse, unauthorized alteration;
15. Damages or liability caused by negligent operation, unsuitable or improper use or operation of the product, including, but not limited to, improper installation, incorrect or careless handling, improper start-up, lack of proper adjustment to control parameter default settings, improper control strategy, incorrect combustion adjustment, disregard of the operating and maintenance instructions or any other instructions supplied with the product;
16. Damage to the product or any of its parts caused by matters outside the control of NTI; and
17. Normal wear and tear and/or consumption of parts including, but not limited to, fuses, gaskets, ignitors and electrodes.

If you have any questions about your coverage under this limited lifetime warranty, please contact NTI at info@ntiboilers.com or the Contact Us form at www.ntiboilers.com. Please review all printed material accompanying the product to learn how to properly care for and maintain your product. Additional information may also be found on our website, listed above.

NTI'S MAXIMUM LIABILITY SHALL NOT EXCEED THE ACTUAL PURCHASE PRICE PAID BY YOU FOR YOUR PRODUCT. IN NO EVENT SHALL NTI BE RESPONSIBLE FOR INDIRECT, INCIDENTAL, CONSEQUENTIAL (INCLUDING WITHOUT LIMITATION DAMAGE TO OR LOSS OF OTHER PROPERTY), OR PUNITIVE DAMAGES, WHETHER SUCH CLAIM OR ACTION IS BASED ON CONTRACT, WARRANTY, NEGLIGENCE, STRICT LIABILITY, OR ANY OTHER LEGAL THEORY.

Some states or provinces do not allow the exclusion or limitation of incidental or consequential damages, so the above limitation or exclusion may not apply to you.

ALL IMPLIED WARRANTIES ARE LIMITED IN THEIR DURATION TO THE APPLICABLE WARRANTY PERIOD STATED ABOVE. ALL IMPLIED WARRANTIES, INCLUDING MERCHANTABILITY AND FITNESS

INDIRECT WATER HEATER AND STORAGE TANK LIMITED LIFETIME WARRANTY

Register product purchases at ntiboilers.com. Retain proof of purchase, installation date and all service records.

FOR A PARTICULAR PURPOSE, ARE DISCLAIMED IN THEIR ENTIRETY AFTER EXPIRATION OF THEIR APPLICABLE WARRANTY PERIOD SET FORTH ABOVE. Some states or provinces do not allow limitations on how long an implied warranty lasts, so the above limitation may not apply to you.

A. What Does This Limited Warranty Cover?

NTI, the manufacturer, warrant that any parts or components of each new indirect water heater or storage tank, will be supplied free of defects in material or workmanship. This warranty replaces any other warranty implied or expressed.

This Limited Warranty covers the tank and all parts in your NTI indirect water heater and storage tank against failure due to defects in materials and workmanship. NTI will replace or, at the sole discretion of NTI, repair any defective part. Any replaced part will be warranted for the longer of i) the unexpired portion

of the original warranty period or ii) 90 days. Labor and all other costs for the inspection or examination, removal and re-installation of defective parts, and transportation costs for defective or replacement parts, are not covered by this warranty.

B. How Long Does the Warranty Last?

Parts Warranty: Two-year limited parts warranty. NTI will repair or replace any component, supplied or manufactured by NTI Boilers Inc., that is found to be defective, for a period of twenty-four (24) months from date of installation, if found to be in compliance with the "Terms and Conditions" of this warranty.

Tank Warranty: Limited lifetime warranty. NTI will, at its discretion, repair or replace a tank found to be defective or malfunctioning, resulting in a leakage of water from the tank, for a period of ten (10) years from the date of installation, and if found to be in compliance with the "Terms and Conditions" of this warranty. For the years following the first 10 years, NTI will provide coverage for a percentage of the material cost of a replacement indirect water heater or storage tank according to the following table:

Year from date of installation	Residential % covered by NTI
11th	75%
12th	
13th	50%
14th	
15th and beyond	25%

Warranty coverage period will commence from the date of installation. If the installation date cannot be confirmed through either the product registration or a contractor's Invoice, coverage will be considered to begin 90 days after NTI shipped the product from its warehouse. This shipping date can be determined by NTI using the product serial number.

C. Terms and Conditions

1. This warranty is VOID if:
 - A) The appliance is not installed and serviced by a licensed and trained heating technician.
 - B) The installation is not in accordance with this manufacturer's manuals, local codes and regulations.
 - C) Tank leaks are a result of corrosive effects caused by abnormal water conditions or outside the following water chemistry requirements:
 - i. Tank water with PH levels outside the limits of 6.0 to 8.0.
 - ii. Tank water with chloride levels (ppm) outside the limits of 0 to 80.
 - iii. Electrical conductivity (EC) exceeding maximum of 125 mS/m @ 25° C
 - iv. Saturation index (LSI) outside the limits of -1.0 to 0.8 @ 80° C
 - D) Deformation occurs due to freezing, improper storage or handling.
 - E) Any repairs or replacements made without authorization by or notification to the manufacturer.
2. This warranty is valid ONLY to the original owner, at the original installation site. The warranty is NOT transferable.
3. The warranty assumes the proper use and care of the appliance and does not cover improper installation, neglect or abuse of the product.
4. Tank replacement warranty covers only the tank for leaks caused by corrosive effects of water under "normal conditions" within the water chemistry limits.
5. NTI Boilers Inc. is not responsible for reimbursement for labor, fuel or punitive damages caused by the operation or failure of the equipment.
6. This warranty does not cover the labor and shipping costs associated with installing a repaired or replaced indirect water heater or storage tank.
7. Decision of warranty repairs or replacements to appliances will be at the discretion of the manufacturer or authorized service representative.

D. How Do You Make A Warranty Claim?

If you believe you have a claim under this limited lifetime warranty, contact a local heating or plumbing contractor of your choice, that is familiar with the operation and service requirement of indirect water heaters and storage tanks. Your contractor will perform a diagnosis to determine the cause of the issue and will work with NTI Boilers Inc. to establish as to whether you may have a claim covered by this Warranty. If your contractor advises you that you may have a claim covered by this warranty, then the contractor can choose to file the claim directly with NTI Boilers Inc. on your behalf, or work through a local wholesale distribution Partner of NTI Boilers Inc. You must make all parts that are subject to a warranty claim available to your contractor for return to NTI. If you have questions about this process or the status of your claim, you may contact the NTI Technical Services at 1-800-688-2575, or email info@ntiboilers.com. You can also find warranty details and procedures at www.ntiboilers.com. **All warranty requests need to be approved by the NTI Warranty Department prior to a replacement or credit being issued. Warranty requests must be processed through an approved NTI distributor or authorized party; warranty requests from other parties will not be accepted and NTI will advise to redirect these requests through authorized wholesalers or sales representatives.**

If you have any questions about your coverage under this limited lifetime warranty, please contact NTI at info@ntiboilers.com or the Contact Us form on www.ntiboilers.com. Please review all printed material accompanying the product to learn how to properly care for and maintain your Product. Additional information may also be found on our website, listed above.

NTI'S MAXIMUM LIABILITY SHALL NOT EXCEED THE ACTUAL PURCHASE PRICE PAID BY YOU FOR YOUR PRODUCT. IN NO EVENT SHALL NTI BE RESPONSIBLE FOR INDIRECT, INCIDENTAL, CONSEQUENTIAL (INCLUDING WITHOUT LIMITATION DAMAGE TO OR LOSS OF OTHER PROPERTY, OR PUNITIVE DAMAGES, WHETHER SUCH CLAIM OR ACTION IS BASED ON CONTRACT, WARRANTY, NEGLIGENCE, STRICT LIABILITY, OR ANY OTHER LEGAL THEORY. Some states or provinces do not allow the exclusion or limitation of incidental or consequential damages, so the above limitation or exclusion may not apply to you.

ALL IMPLIED WARRANTIES ARE LIMITED IN THEIR DURATION TO THE APPLICABLE WARRANTY PERIOD STATED ABOVE. ALL IMPLIED WARRANTIES, INCLUDING MERCHANTABILITY AND FITNESS FOR A PARTICULAR PURPOSE, ARE DISCLAIMED IN THEIR ENTIRETY AFTER EXPIRATION OF THEIR APPLICABLE WARRANTY PERIOD SET FORTH ABOVE. Some states or provinces do not allow limitations on how long an implied warranty lasts, so the above limitation may not apply to you.

NTI Boilers Inc., 30 Stonegate Drive, Saint John, NB, Canada E2H 0A4;
Technical Assistance: 1-800-688-2575 or info@ntiboilers.com
Rev: 24/07/16

JOIN THE PROS!

Participate in a training session today!

Contact us at:

info@ntiboilers.com

to get in touch with our training team and learn about available dates in your area.



Reach out to your local representative now!

Scan the QR code or visit www.ntiboilers.com/sales



Follow us on social media!



[@ntiboilers](https://www.facebook.com/ntiboilers)



[@ntitraining](https://www.youtube.com/ntitraining)

www.ntiboilers.com



Products you need
from people who care



30 Stonegate Drive, Saint John, NB E2H 0A4 | ntiboilers.com | info@ntiboilers.com
Toll: 1-800-688-2575 | Direct: 506-657-6000

MEMBER OF THE ARISTON GROUP

©2024 NTI Boilers Inc. All rights reserved. Subject to change without notice.