

Project Name: _____ Date: _____
 Location: _____
 Engineer: _____
 Contractor: _____ Rep: _____

1 – GENERAL SPECIFICATIONS

Product Features:

- ✓ Certified to ANSI Z21.13 / CSA 4.9 Gas-fired Boiler Standard
- ✓ ASME "H" stamped boiler, designed and constructed in compliance with the ASME Boiler and Pressure Vessel Code Section IV
- ✓ Maximum operating pressure 50 psi [344.7 kPa]
- ✓ SA-268 S43940 Stainless Steel Heat Exchanger
- ✓ Modulating burner, up to 8:1 turndown ratio
- ✓ Direct Spark Ignition
- ✓ Instantaneous domestic hot water
- ✓ Wall (standard) or floor mounting (w/ opt. kit, NTI part # 84630)
- ✓ Zero clearance to combustibles
- ✓ 151-199 MBH [151,000-199,000 BTU]
- ✓ Field conversion from Natural Gas (factory) to Propane
- ✓ Optional Sidewall vent kits
- ✓ 120VAC outlet for condensate pump
- ✓ On/Off switch

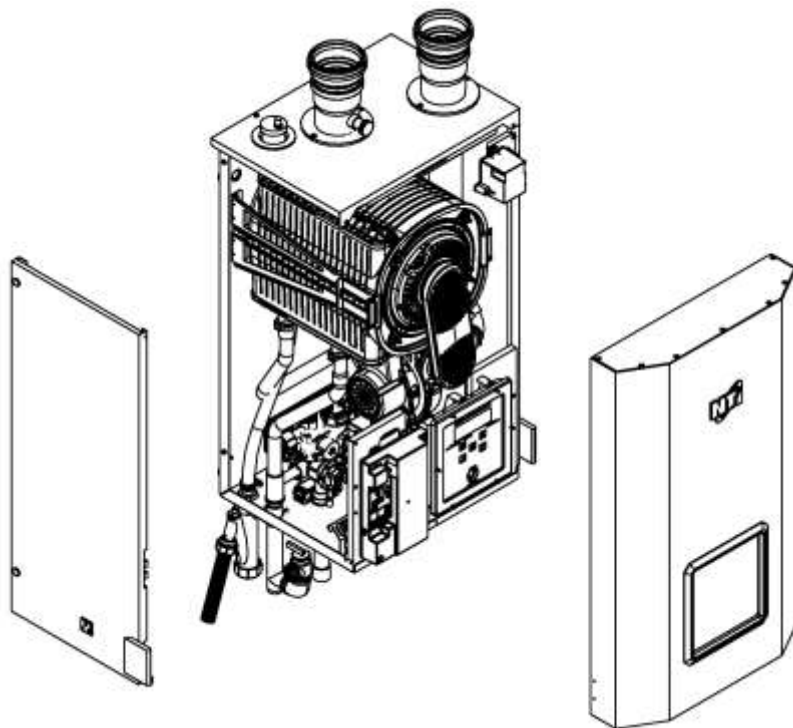

Factory Supplied Items

- ✓ 10K thermistor outdoor sensor
- ✓ 30PSI [206.8 kPa] ASME Relief Valve
- ✓ 60PSI [413.7 kPa] Pressure Gauge
- ✓ Condensate Trap
- ✓ Integrated DHW heat exchanger
- ✓ Integrated DHW flow sensor
- ✓ Integrated boiler circulator
- ✓ Integrated diverter valve
- ✓ Low-Loss header w/ 1" sweat connections
- ✓ Water Pressure Sensor

Control Features

- ✓ Integral microprocessor safety control
- ✓ Domestic Hot Water Priority timer
- ✓ Domestic Hot Water pre-heat option
- ✓ Outdoor Reset
- ✓ Warm weather shut down
- ✓ Freeze protection
- ✓ Cascade up to 16 Tx series boilers
- ✓ Outdoor reset temperature boost
- ✓ Service reminder
- ✓ Adjustable pump post purge
- ✓ Run time accumulation
- ✓ Night setback option
- ✓ Lockout and error history

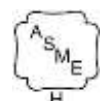
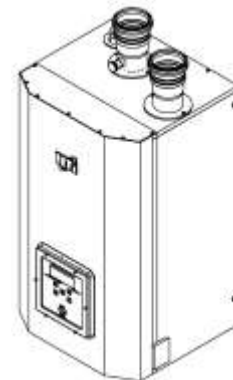

Model Specifications

Model	Water Conn, in.	DHW Connection NPT, in.	Gas Connection NPT, in.	Vent/Air-Intake Pipe Diameter in.	Vent/ Air-Inlet Max. Length, Ft.		Approx. Wt. w/Water lb.
					2 in. Venting	3 in. Venting	
Tx151C	1" Female Sweat	¾ (male)	½ (Female)	2 or 3	100	150	98
Tx200C	1" Female Sweat	¾ (male)	½ (Female)	3	NA	100	109

Heating Specifications

Model	Input			*Space Heating Capacity BTU/hr	AFUE %	Space Heating NET I=B=R Rating BTU/hr
	Min BTU/hr	Max BTU/hr DHW	Max BTU/hr Space Heating			
Tx151C	18,875	151,000	80,000	74,000	95	64,000
Tx200C	24,875	199,000	120,000	111,000	95	96,000

DHW Flow Rate Specifications (GPM)

Tx151C		Inlet Water Temperature (°F)						
		40	45	50	55	60	65	70
Outlet Water (F)	110	3.9	4.5	4.5	4.9	5.4	6.0	6.7
	115	3.6	3.6	4.2	4.5	4.9	5.4	6.0
	120	3.4	3.6	3.9	4.2	4.5	4.9	5.4
	125	3.2	3.4	3.6	3.9	4.2	4.5	4.9
	130	3.0	3.2	3.4	3.6	3.9	4.2	4.5
	135	2.8	3.0	3.2	3.4	3.6	3.9	4.2
	140	2.7	2.8	3.0	3.2	3.4	3.6	3.9

Tx200C		Inlet Water Temperature (°F)						
		40	45	50	55	60	65	70
Outlet Water (F)	110	5.1	5.5	6.0	6.5	7.2	8.0	9.0
	115	4.8	5.1	5.5	6.0	6.5	7.2	8.0
	120	4.5	4.8	5.1	5.5	6.0	6.5	7.2
	125	4.2	4.5	4.8	5.1	5.5	6.0	6.5
	130	4.0	4.2	4.5	4.8	5.1	5.5	6.0
	135	3.8	4.0	4.2	4.5	4.8	5.1	5.5
	140	3.6	3.8	4.0	4.2	4.5	4.8	5.1



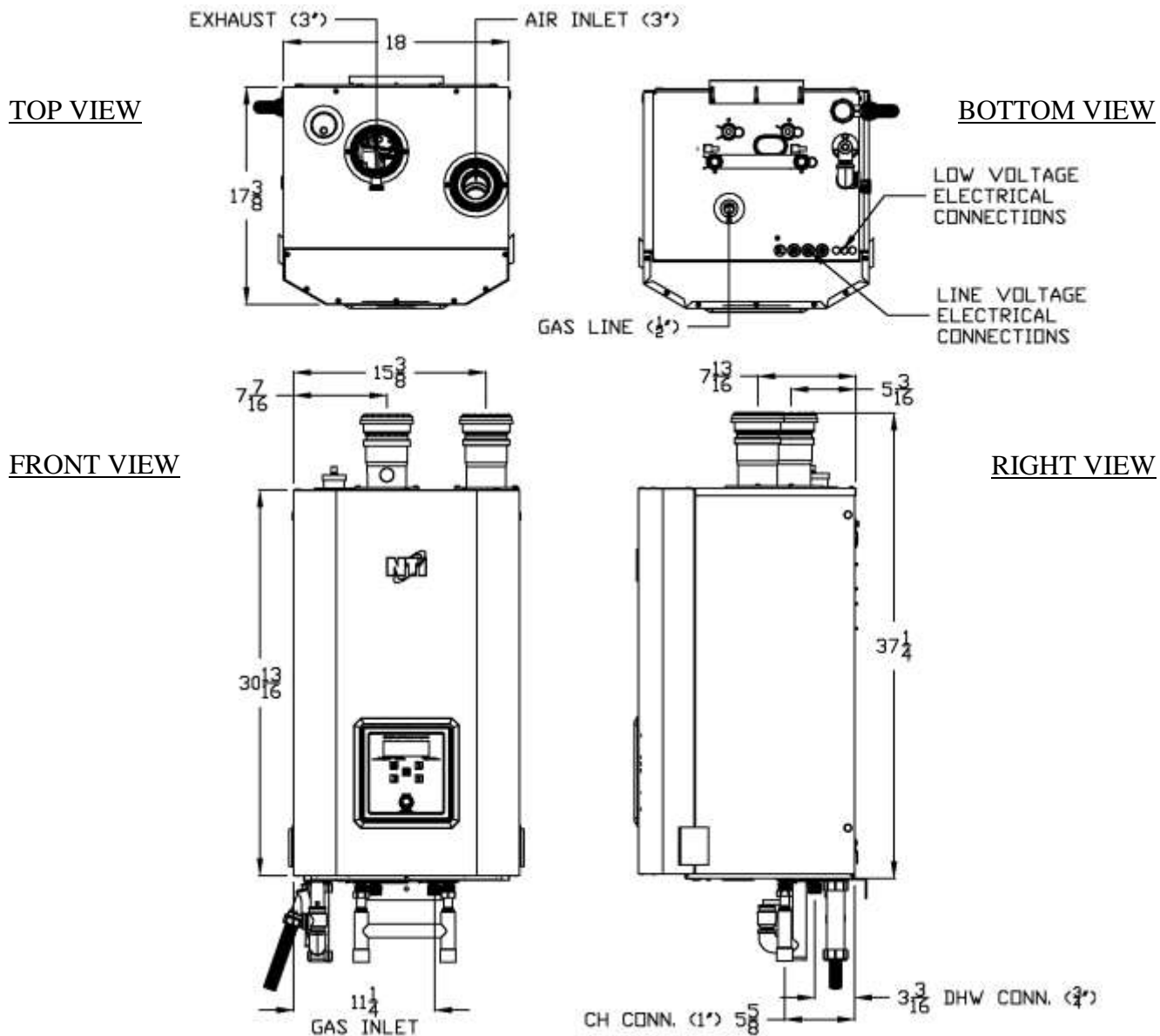

RECOMMENDED CLEARANCES [IN.]

Front	Top	Sides	Back	Bottom	Flue Pipe
36	24	12	0	24	1



