



Trinity Tft285 High Efficiency Gas-Fired Condensing Boiler

Submittal Sheet

Section 1 - Specifications
Section 2 - Dimensions
Section 3 - Electrical

Project Name: _____ Date: _____
 Location: _____
 Engineer: _____
 Contractor: _____ Rep: _____

1 SPECIFICATIONS

General Specifications

- ▶ Product Features
 - Certified to ANSI Z21.13 / CSA 4.9 Gas-fired Boiler Standard
 - ASME "H" stamped boiler, designed and constructed in compliance with the ASME Boiler and Pressure Vessel Code Section IV
 - SA240-S43932 Stainless Steel Heat Exchanger
 - Maximum operating pressure 80 psi
 - Field conversion from Natural Gas (factory) to Propane
 - Modulating burner, 10:1 turndown
 - Direct Spark Ignition
 - Wall (standard) or floor mounting (w/ opt. kit, NTI part # 84630)
 - Zero clearance to combustibles (clearances required for service)
 - Certified as Direct Vent (sealed combustion) or for use with indoor combustion air
- ▶ Optional Side Wall Vent Terminal Kit (NTI Part # 85062, 84357 & 82666)
- ▶ Factory Supplied Items
 - 10k Outdoor sensor (System sensor optional)
 - 30 PSI ASME Pressure Relief Valve
 - Pressure/Temperature Gauge
- ▶ Control Features
 - Integral microprocessor safety control
 - 2 central heat inputs (high & low temperature)
 - Domestic Hot Water Priority
 - Outdoor reset
 - Warm weather shutdown
 - Lead-Lag up to 8 Tft series boilers
 - Integrated Modbus RTU for connection to BMS gateways

Water Connections NPT, in.	Gas Connection NPT, in.	Vent/Air-inlet Pipe Diameter, in.	Vent/Air-inlet Max. Length, ft.	Approx. Weight with Water lb.
1-1/4 (Male)	3/4 (Male)	3	150	180

Performance Specifications

Input Modulation, MBH	DOE Heating Capacity, MBH	Net I=B=R Rating, MBH	AFUE, %
28.5 - 285	263	228	95

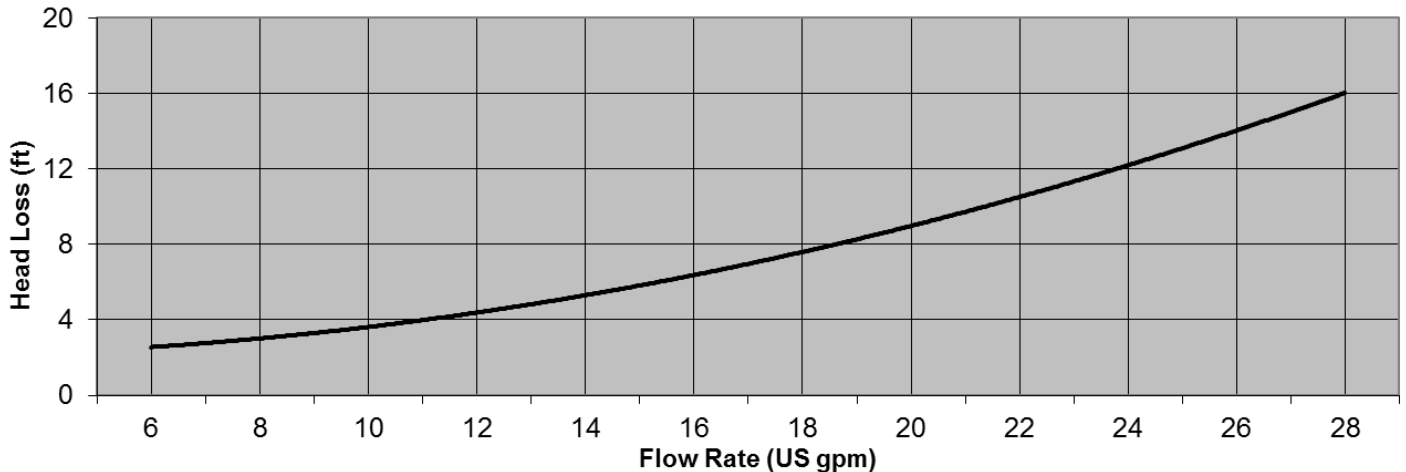

NTI Boilers Inc. 30 Stonegate Dr., Saint John, NB E2H 0A4 Canada
 Technical Services: 1-800-688-2575 Fax: 1-506-432-1135 Web: <http://www.ntiboilers.com>
 NTI Boilers Inc. reserves the right to change these specifications without notice



Trinity Tft285 High Efficiency Gas-Fired Condensing Boiler

Submittal Sheet

2 DIMENSIONS

Product Dimensions – in.

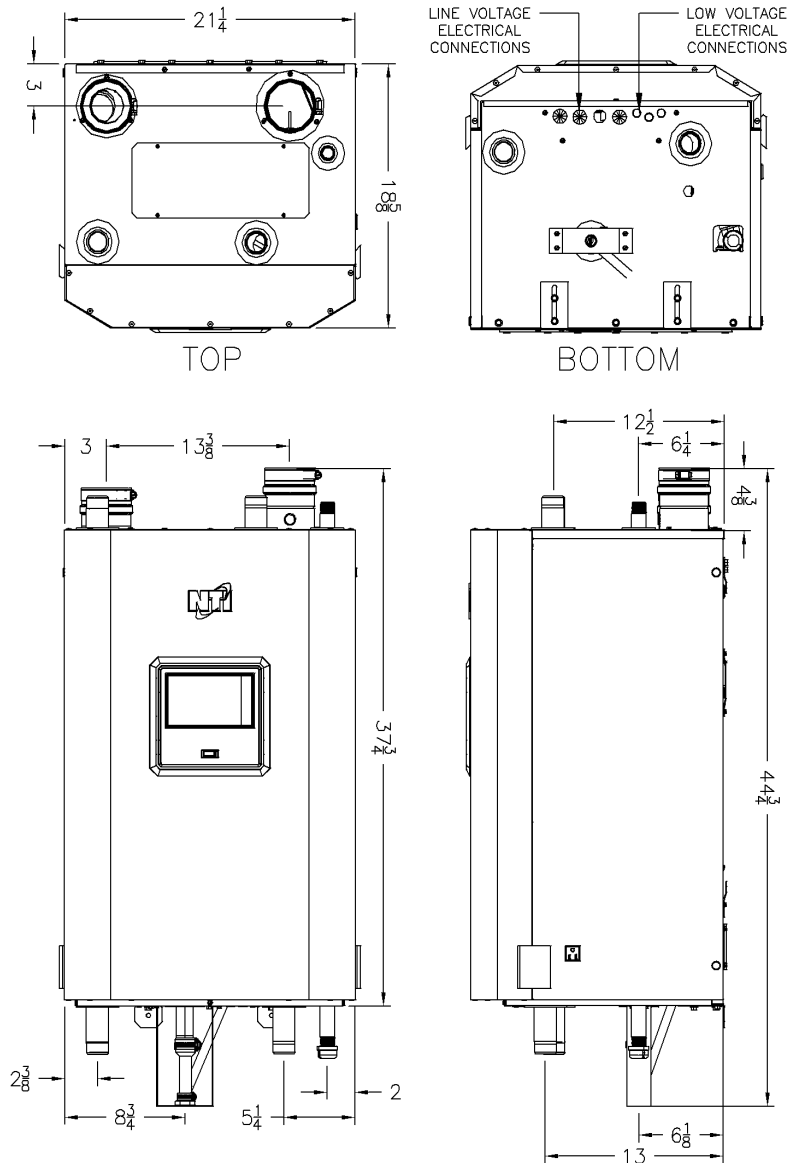

Recommended Clearances – in. [mm]

Front	Top	Sides	Back	Bottom	Flue Pipe
36 [914]	24 [610]	12 [305]	0	24 [610]	1 [25]



NTI Boilers Inc. 30 Stonegate Dr., Saint John, NB E2H 0A4 Canada
 Technical Services: 1-800-688-2575 Fax: 1-506-432-1135 Web: [http:// www.ntiboilers.com](http://www.ntiboilers.com)
 NTI Boilers Inc. reserves the right to change these specifications without notice



Trinity Tft285 High Efficiency Gas-Fired Condensing Boiler

Submittal Sheet

3 ELECTRICAL

Simplified Wiring Diagrams

Line Voltage Electrical:

- ▶ 120VAC / 60 Hz / 1 Phase / 12 Amp
- ▶ Barrier Strip for field wiring terminations
- ▶ 3 Pump outputs
 - Indirect Domestic Hot Water (Pump A)
 - Boiler (Pump B)
 - Central Heat (Pump C)

Note: Pumps are field supplied.

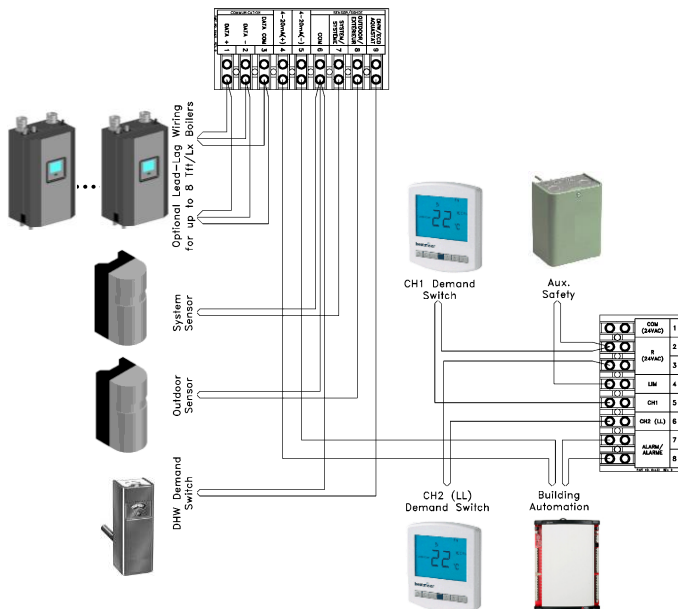
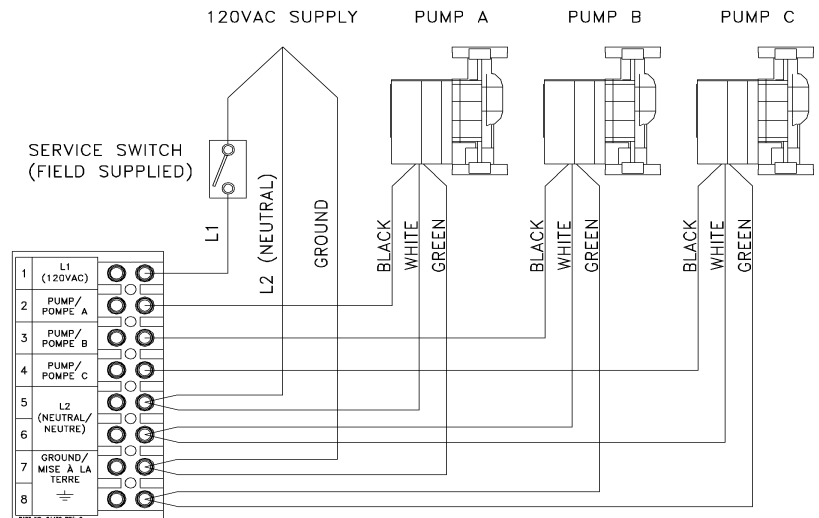

Low Voltage Electrical:

- ▶ Barrier Strip for field wiring terminations
- ▶ 120/24 VAC Transformer 40VA (factory supplied)
- ▶ Inputs
 - CH1 thermostat (by others)
 - CH2 thermostat (by others)
 - Indirect DHW aquastat (by others) or DHW Tank sensor (factory option)
 - External Limit (by others)
 - Outdoor sensor (factory supplied)
 - System sensor (factory option)
 - 4-20mA external modulating control (by others)
- ▶ Outputs
 - Alarm dry contact (24VAC 0.63A max.)
- ▶ EIA-485 Modbus communications for Lead-Lag
- ▶ EIA-485 Modbus to BMS gateways (not shown). Optional available gateways:
 - BACnet/N2- NTI part # 84946
 - LonWorks- NTI part # 84947

