

Odyssey

Model Numbers: CT80-250

Version Date: 2018-12-07



INSTALLATION AND OPERATION INSTRUCTIONS

ODYSSEY OIL BOILER

Venting Applications: Natural Draft or Direct Vent (Balanced Flue)

TABLE OF CONTENTS

1.0	INTRODUCTION	3
2.0	SPECIFICATIONS	6
3.0	BOILER LOCATION	8
4.0	BOILER ASSEMBLY	9
5.0	GENERAL VENTING	14
6.0	NATURAL DRAFT APPLICATIONS	15
7.0	DIRECT VENT APPLICATIONS	18
8.0	BOILER PIPING	25
9.0	FIELD WIRING	27
10.0	INSTALLATION CHECKLIST	33
11.0	ANNUAL MAINTENANCE AND INSPECTION	35
12.0	PARTS LIST	37
13.0	WARRANTY	41

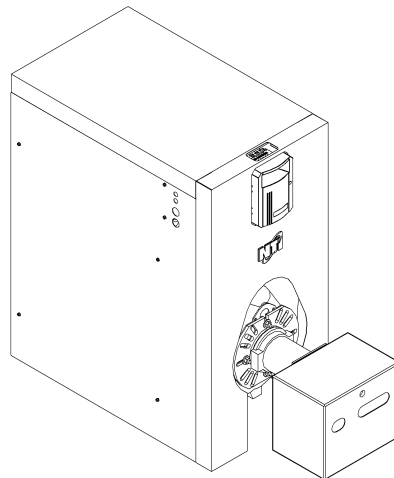
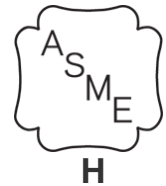

Odyssey CT80-250

HAZARD SYMBOLS AND DEFINITIONS



Danger Sign: Indicates a hazardous situation which, if not avoided, will result in serious injury or death.



Warning Sign: Indicates a hazardous situation which, if not avoided, could result in serious injury or death.



Caution Sign plus Safety Alert Symbol: Indicates a hazardous situation which, if not avoided, could result in minor or moderate injury.



Caution Sign without Safety Alert Symbol: Indicates a hazardous situation which, if not avoided, could result in property damage.

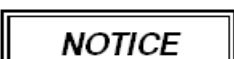

Notice Sign: Indicates a hazardous situation which, if not avoided, could result in property damage.



This Boiler must be installed by a licensed and trained Heating Technician or the **Warranty is Void**. Failure to properly install this unit may result in property damage, serious injury to occupants, or possibly death.

Read Before Proceeding

If you do not follow these instructions exactly, a fire may result causing property damage, serious injury or death.

FOR YOUR SAFETY, READ BEFORE OPERATING**BEFORE OPERATING:**

- A. Do not start burner unless the smoke hood, clean out door, temperature limit, flue breeching, and burner door (if applicable) are secured in place and the boiler is filled with water.
- B. Do not attempt to starter burner when excess oil has accumulated in combustion chamber, when unit is full of vapour, or when combustion chamber is very hot.
- C. Do not use gasoline, crankcase drainings, or any oil containing gasoline.
- D. Never burn garbage or paper in the unit and never leave combustible material around it.
- E. Always keep the oil supply valve shut off if the burner is shut down for an extended period of time.
- F. Do not tamper with the unit or controls - call your service personnel for service and maintenance.
- G. Do not use this boiler if any part has been under water. Immediately call a qualified service technician to inspect the boiler and to replace any part of the control system and any oil control which has been under water.

OPERATING INSTRUCTIONS

1. STOP! Read the safety information above very carefully.
2. Initial start-up and start-ups after periods of extended/seasonal shutdown must be performed by a qualified service technician.
3. Check the boiler area for proper clearances.
4. Turn the thermostat(s) up.
5. Turn the emergency power isolation switch on.
6. If ignition does not occur, follow the instructions "To Turn Off Oil Boiler" and call a qualified service technician.

TO TURN OFF OIL BOILER

1. STOP! Read the safety information above very carefully.
2. Turn off emergency power isolation switch. Should be mounted on the wall near entrance to boiler room.



Void Warranty - This boiler must have water in it whenever the burner is on or it will damage the unit and void the warranty. Failure to follow these instructions may result in serious injury or death.



Fuel Oil - Use only No. 2 fuel oil for boiler models listed in this manual. Failure to follow these instructions may result in severe personal injury, property damage, or death.



Low Water Cut Off (LWCO) - To take advantage of the HydroStat's LWCO feature, the Odyssey is equipped with a special immersion well call the Electro-well™. Failure to use the Electro-well™ provided with the boiler will over-ride the LWCO feature and allow the boiler to operate during low water conditions which may result in over heating, fire, serious injury, or death.



Oil Supply Valve - Always keep the oil supply valve shut off if the burner is shut down for an extended period of time.

1.0 INTRODUCTION

General Installation Requirements

The installation of your NTI Odyssey oil boiler shall be in accordance with these instructions and the regulations of the authorities having jurisdiction and must comply with the following codes and standards:

United States

- State and local plumbing, heating, and electrical codes
- NFPA 70 National Electric Code
- NFPA 31 Installation Code for Oil Burning Equipment
- Standard ANSI/ASME CSD-1, Controls and Safety Devices for Automatically Fired Boilers (if applicable)

Canada

- Provincial and local plumbing, heating, and electrical codes
- CSA C22.1 Canadian Electrical Code Part One
- CSA B139 Installation Code for Oil Burning Equipment

The Odyssey is a knock-down boiler constructed of cast iron. The venting application needs to be decided in advance, either Natural Draft or Direct Vent, prior to ordering the boiler as burner packages will vary depending on the venting application. The boiler package comes in three sections and requires field assembly. Check your boiler package when it arrives and ensure it includes the following:

1. Boiler
2. Jacket
3. Burner Kit

This document pertains to the correct installation and operation of NTI Odyssey oil boilers for Natural Draft and Direct Vent models. The instructions detailed in this document supersede any and all previous instructions provided by NTI, written or otherwise. The warranty is included in the Installation and Operation manual. Each unit comes complete with the following documentation:

1. Installation and Operating Instructions
2. Users Manual



Read and understand this entire document prior to proceeding with the installation of the Odyssey. Failure to follow the instructions outlined in this document will result in property damage, serious injury or death.

User Responsibilities

This boiler must be installed and serviced by a qualified installer or service technician. This boiler must be serviced and inspected annually. As the User/Owner of this equipment, you are responsible for ensuring the maintenance is performed at the required intervals. See “Users Manual”.



Failure to have the boiler properly serviced and inspected on a regular basis by a qualified service technician may result in property damage, serious injury or death.

Installer Responsibilities

As the installing technician it is your responsibility to ensure the installation is performed in accordance with this instruction manual as well as any applicable local or National installation codes. It is also your responsibility to inform the User/Owner of their obligation with respect to the above description under “User Responsibilities”. Failure to follow this warning could result in fire, serious injury, or death.

Natural Draft Applications



Natural Draft Applications - All Odyssey models are certified as Natural Draft boilers which require a “Chimney System”. The exhaust gases must be vented directly to the chimney. Failure to follow these instructions will result in serious injury or death.



Blocked Vent Switch - All Natural Draft Odyssey boilers require a Blocked Vent Switch which is factory supplied and packaged with the burner kit and is mandatory in Canada. The Block Vent Switch must be field installed as per the instructions in this manual and the manufacturers instructions included with the switch. Failure to follow the specified instructions may result in fire, property damage, personal injury, or death.

Table 1-1 Odyssey Boiler Packages (Natural Draft)

MODEL	BOILER PART NUMBER	BOILER PACKAGE			Burner Kit Contents (Natural Draft)										
		Boiler Only	Jacket	Burner Kit Natural Draft ¹	Burner	Blast Tube	Nozzle ²	HydroStat 3250	Hydrolevel Electro-Well	Tridicator	OD Sensor	Relief Valve	Supply Tee	Block Vent Switch	
Riello Burner	CT80 ⁴	CT80.3F9A1	CT80	82002	F3.CT	10618	84024	0.65 60° W	84787	84788	81342	83604	84877	84829	82905
	CT90 ⁴														
	CT100 ⁴														
	CT120	CT120.3G9A1	CT120	82003	F5.CT ³	10630	0.85 60° B								
	CT150														
	CT180 ⁴														
	CT215	CT215.1H9A1	CT215	82004	F10.CT	10632	84654	1.5 60° W							
	CT230														
CT250															
CT250															
Beckett Burner	CT80 ⁴	CT80.3P9A1	CT80	82002	NYC601CT	81031	0.75 70° B	84787	84788	81342	83604	84877	84829	82905	
	CT90 ⁴														
	CT100 ⁴														
	CT120	CT120.3P9A1	CT120	82003	NYC602CT	81032	1.10 60° B								
	CT150														
	CT180 ⁴														
	CT215	CT215.3P9A1	CT215	82004	NYC602CT	81032	1.10 60° B								
	CT230														
CT250															

Notes:

- ¹ Boiler manual packaged with the Burner Kit.
- ² Nozzle size included in Burner Kit. See below, “Attention: Nozzle Sizes”.
- ³ Burner and blast tube comes assembled c/w nozzle specified in this table. Nozzle may need to be changed depending on boiler output.
- ⁴ Models CT80-100 and CT180 are no longer offered as they do not meet new minimum efficiency regulations.



Nozzle Sizes - The nozzle sent with each respective boiler burner kit is for the minimum firing rate specified for that burner. To obtain a different firing rate, replace the factory supplied nozzle with the appropriate nozzle that meets the desired output. Refer to Tables 2-1 to 2-2 in Section 2.0 for nozzle specifications and performance ratings for Natural Draft boilers.

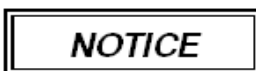

Manufacturer’s Instructions – For complete instructions on installation and control operation, refer to the manufacturer’s instructions included with the Temperature Limit, Burner Package, and Blocked Vent Switch.

Direct Vent Applications

There are four Odyssey models, CT90-120, certified for installation as a Direct Vent boiler. This balanced flue system requires a special venting system in order to pressurize and essentially equalize the inlet and outlet pressure to ensure normal operation. Refer to section “General Venting” and “Specifications” for more details on Direct Vent applications and termination kits.



Balanced Flue Applications - Models CT90-120 are also certified as Direct Vent boilers and must be ordered as such. Balance flue systems must use the NTI approved venting system. Note that the Direct Vent Terminal and Insulated Flex Pipe are sold separately (see Table 7-2 Direct Vent Kit Components for more details). This “Special Venting System” is designed for pressurized venting with NTI Direct Vent boilers. The exhaust gases must be piped directly to the outdoors using the vent materials and rules outlined in these instructions. Failure to follow these instructions will result in serious injury or death.

Table 1-2 Odyssey Boiler Packages (Direct Vent)

MODEL	BOILER PART NUMBER	BOILER PACKAGE			Burner Kit Contents (Direct Vent)									
		Boiler Only	Jacket	Burner Kit Direct Vent ¹	Burner	Blast Tube	Nozzle ²	HydroStat 3250	Hydrolevel Electro-Well	Tridicator	OD Sensor	Relief Valve	Supply Tee	Direct Vent Kit ⁴
Riello Burner	CT90 ⁶	CT90.3T9A4	CT80	82002	BF5.CT ³	81122	0.85 60°B	84787	84788	81342	83604	84877	84829	Table 7-2
	CT100 ⁶													
	CT120	CT120.3T9A4	CT120	82003	BF5.CT ³	81122	0.85 60°B							

Notes:

- ¹ Boiler manual packaged with the Burner Kit.
- ² Nozzle size included in the Burner Kit. See below, “Attention: Nozzle Sizes”.
- ³ Burner and blast tube comes assembled c/w nozzle specified in this table. Nozzle may need to be changed depending on boiler output.
- ⁴ Direct Vent Terminal not included in Kit. Refer to Table 7-2 for a list of components that must be ordered separately.
- ⁵ Riello BF5 burners are single line gravity feed. See burner manufacturers’ instructions for more details.
- ⁶ Models CT80-100 are no longer offered as they do not meet new minimum efficiency regulations.

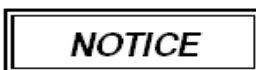

Manufacturer’s Instructions - For complete instructions on installation and control operations, refer to the manufacturer’s instructions included with the Temperature Limit, Burner Package, and Direct Vent Terminal.



Nozzle Sizes - The nozzle sent with each respective boiler burner kit is for the minimum firing rate specified for that burner. To obtain a different firing rate, replace the factory supplied nozzle with the appropriate nozzle that meets the desired output. Refer to Table 2-3 in Section 2.0 for nozzle specifications and performance ratings for Direct Vent boilers.



Intakes/Vents - Failure to keep the Vent and Combustion Air Intake clear of ice, snow, and other debris may result in property damage, serious injury, or death.



Energy Saving Feature - This boiler is equipped with a feature that saves energy by reducing the boiler water temperature as the heating load decreases. This feature is equipped with an override which is provided primarily to permit the use of an external energy management system that serves the same function. THIS OVERRIDE MUST NOT BE USED UNLESS AT LEAST ONE OF THE FOLLOWING CONDITIONS IS TRUE :

- An external energy management system is installed that reduces the boiler water temperature as the heating load decreases.
- This boiler is not used for any space heating.
- This boiler is part of a modular or multiple boiler system having a total input of 300,000 BTU/hr or greater.
- This boiler is equipped with a tankless coil.

2.0 SPECIFICATIONS

Natural Draft Application

IMPORTANT

Draft Settings (Natural Draft) - The Odyssey is designed to operate with -.03" w.c. draft in the flue breaching. For proper operation, there must be enough natural or mechanical draft. Due to the design of the Odyssey, it may operate at a positive over fire pressure up to +.20 at -.03 draft. Due to installation and equipment variations, recommended air settings are a guideline and will require alteration. See Tables 2-1 and 2-2.

NOTICE

Insertion Depth (Natural Draft) - See General Notes section in Tables 2-1 and 2-2.

Table 2-1 Riello Burners with Odyssey Boilers (Natural Draft)

Boiler Model	Input GPH (US)	Heating Capacity MBH	Net I=B=R Rating Water MBH	AFUE Efficiency %	Pump PSIG	Delevan Nozzle	Recommended Burner Settings		
							Burner	Air	Turbulator
CT80 ⁸	0.65	77	67	83.6%	117	0.60 60°W	F3	5	0
CT90 ⁸	0.75	88	77	83.0%	133	0.65 60°W	F3	7	0
CT100 ⁸	0.85	99	86	82.4%	128	0.75 60°W	F3	7	2
CT120	1.00	121	105	85.1%	138	0.85 60°W	F5	3	2
CT150	1.25	149	130	84.0%	156	1.00 60°W	F5	5	2
CT180 ⁸	1.50	176	153	82.8%	144	1.25 60°W	F5	9	3.5
CT215	1.75	212	184	85.8%	136	1.50 60°W	F10	3.5	2
CT230	1.85	223	194	85.5%	152	1.50 60°W	F10	7	2
CT250	2.00	240	209	85.0%	178	1.50 60°W	F10	6	3

General Notes:

- ¹ Output is "Heating capacity" for models CT80-250.
- ² Models CT80-250 use Riello 40 series burners.
- ³ Energy ratings for C85-250 have been confirmed by AHRI.
- ⁴ Models CT80-100 - F3 burners have an insertion depth of 2.375".
- ⁵ Models CT120-180 - F5 burners come assembled with an insertion depth of 2.375".
- ⁶ Models CT215-250 - F10 burners have an insertion depth of 2.75".
- ⁷ F10 burner heads - If head carbons on models CT215-250, reduce turbulator setting and increase air a little.
- ⁸ Models CT80-100 and CT180 are no longer offered as they do not meet new minimum efficiency regulations.

Table 2-2 Beckett Burners with Odyssey Boilers (Natural Draft)

Boiler Model	Input GPH (US)	Heating Capacity MBH	Net I=B=R Rating Water MBH	AFUE Efficiency %	Pump PSIG	Delevan Nozzle	Recommended Burner Settings			
							Burner	Head	Shutter	Band
CT80 ⁴	0.65	77	67	83.6%	117	0.60 60°W	MBL1	-	5	0.5
CT90 ⁴	0.75	88	77	83.0%	133	0.65 60°W	MBL1	-	6	1
CT100 ⁴	0.85	99	86	82.4%	128	0.75 60°W	MBL1	-	10	0
CT120	1.00	121	105	85.1%	138	0.85 60°W	MDV1	0	5	1
CT150	1.25	149	130	84.0%	156	1.00 60°W	MDV1	1	6	2
CT180 ⁴	1.50	176	153	82.8%	144	1.25 60°W	MDV1	2	8	3
CT215	1.75	212	184	85.8%	136	1.50 60°W	MDV1	3	10	6
CT230	1.85	223	194	85.5%	152	1.50 60°W	MDV1	4	10	5
CT250	2.00	240	209	85.0%	178	1.50 60°W	MDV1	4	8	7

General Notes:

- ¹ Models CT80-250 use Beckett AFG50 series burners.
- ² Energy ratings for C85-250 have been confirmed by AHRI.
- ³ Models CT80-250 - MBL1 (NYC601) burners and MDV1 (NYC602) have an insertion depth of 3.75.
- ⁴ Models CT80-100 and CT180 are no longer offered as they do not meet new minimum efficiency regulations.

Direct Vent Application**IMPORTANT**

Draft Settings (Direct Vent) - Due to the design of the balanced flue system, the Odyssey will operate at a positive draft pressure and a positive over fire pressure at all times. It is designed to operate with a maximum stack draft of 0.25" w.c. and a maximum over fire draft of 0.33" w.c. when little or no wind is present. In extreme wind conditions, the maximum stack draft is 0.35" w.c. and the maximum over fire draft is 0.45" w.c. Due to installation and equipment variations, recommended air settings are a guideline and will require alteration. See Table 2-3.

NOTICE

Insertion Depth (Direct Vent) - See General Notes section in Table 2-3.

Table 2-3 Riello Burners with Odyssey Boilers (Direct Vent)

Boiler Model	Input GPH (US)	Heating Capacity MBH	Net I=B=R Rating Water MBH	AFUE Efficiency %	Pump PSIG	Delevan Nozzle	Recommended Burner Settings		
							Model	Air	Turbulator
CT90 ⁴	0.75	88	77	83.0%	133	0.65 60°W	BF5	4	0
CT100 ⁴	0.85	99	86	82.4%	128	0.75 60°W	BF5	5	0
CT120	1.00	121	105	85.1%	138	0.85 60°W	BF5	6	1.5

General Notes:

- ¹ Models CT90-120 use Riello 40 series burners.
- ² Energy ratings for CT90-120 have been confirmed by AHRI.
- ³ Models CT90-120 - BF5 burners come assembled with an insertion depth of 2.375".
- ⁴ Models CT80-100 are no longer offered as they do not meet new minimum efficiency regulations.

Boiler Characteristics**Table 2-4 Odyssey Boiler Characteristics**

Description	Boiler Shell		
	CT80-100	CT120-180	C215-250
Boiler Shell Weight [lbs]	260	390	500
Fuel Type	No. 2 Oil		
Water Connections – NPT [in.]	1.25	1.25	1.25
Dimensions H x W x D [in.]	30 x 15.5 x 17.5	30 x 15.5 x 25.5	30 x 15.5 x 33.5
Approx. Boiler Weight with Water [lbs]	290	435	560
Approx. Boiler Water Content [usg]	3.6	5.4	7.3
Stack Size	5	5	5
Electrical Rating	120V / 1Ph / 60Hz / < 12A		

3.0 BOILER LOCATION

In all cases, the Odyssey must be installed indoors in a dry location where the ambient temperature must be maintained above freezing and below 100°F [38°C]. All boiler components must be protected from dripping, spraying water, or rain during operation and servicing. Consider the proximity to the following when determining the best boiler location.

- System Water Piping
- Oil Supply
- Electrical Power
- Combustion Air / Ventilation Air
- Chimney

WARNING Components - Water or flood damaged components must be replaced immediately with new components (see parts list). Failure to do so may result in fire, serious injury, or death.

Clearances - Clearances to combustibles represent the minimum clearances required for safety and service. Recommended clearances are for ease of piping installation, annual maintenance, and service access. Refer to Table 3-1 and Figure 3-1.

Table 3-1 Minimum Clearances for Installation and Service

Model	Clearances	Dimensions - inches [mm]					
		Front	Rear	Top	Sides	Flue Pipe ^{1,2}	Floor
CT80-250	To Combustibles	24 [610]	5 [124]	12 [305]	5 [124]	9 [228]	Combustible
	Recommended	36 [915]	24 [610]	24 [610]	24 [610]	9 [228]	Combustible

Notes:

¹ Minimum clearances from flue pipe to combustibles is 9” for single-wall pipe; 6” for double-wall pipe (Type-L). See “Clearances to Combustibles” in Direct Vent Installation Instructions on page 24, for clearance to insulated flex-vent.

² Flue pipe clearances take precedence over all other clearances.

IMPORTANT Boiler Location - Even if all installation codes are met, good judgment and common sense must also be used when selecting a boiler location. Refer to minimum clearances in Table 3-1 and vent clearances for chimney or direct vent applications.

Figure 3-1 Minimum Clearances to Combustibles

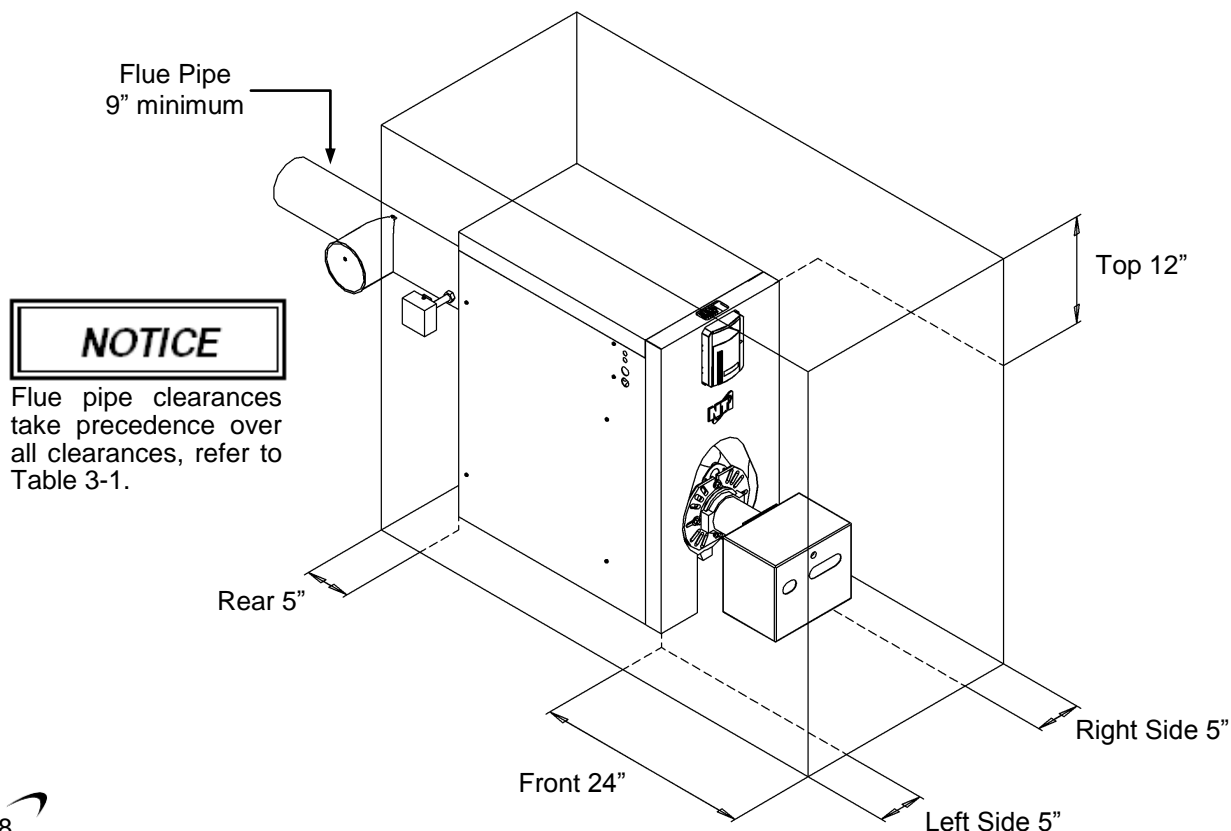

4.0 BOILER ASSEMBLY

The installation of the boiler shall be in accordance with the authorities having jurisdiction and must comply with Standard CSA B139 (Canada) or NFPA 31 (USA).



WARNING

Fiberglass Materials - Before installing the insulation, read “Handling Instructions” in Section 11.0 and the protective measures recommended when handling fiberglass.

Assembly Procedure

The boiler assembly procedure is to be completed in sequence and in conjunction with the illustrated assembly diagrams, Figures 4-1 through 4-12.

1. Do not fully tighten screws until jacket assembly is complete.
2. Level the boiler before commencing jacket installation.
3. Install rear brackets on the boiler, secure by tightening nuts (Figures 4-1 to 4-3).
4. Install front brackets on the boiler, secure by tightening nuts (Figures 4-4 to 4-6).
5. Install fiberglass insulation on the boiler by wrapping it around the heat exchanger. Secure with factory supplied twine (Figure 4-7).
6. Remove all protective plastic film on the jacket panels before installing.
7. Attach side panels to front and back brackets (Figure 4-8).
8. Install control panel between side panels, secure with screws provided (Figure 4-9).
9. Mount HydroStat 3250 by sliding it down over the tabs on the control panel. Secure in place with hold down bracket as shown (Figure 4-10).
10. Mount bottom back panel to boiler (Figure 4-10); Recommend installing top back panel after flue breeching connected, sealed, and supported. (See also Figure 6-1 Flue Breeching).
11. Fully tighten all jacket screws to secure panels in place.
12. Insert sensor fully into the Electro-well™ or boiler overheating may occur (Figure 4-11). See “Danger” warning on page 11.
13. Feed the green wire, connected to the boiler ground screw, through the knockout in the back of the HydroStat. Connect the other end of the wire to the HydroStat ground screw inside the control (green screw).
14. Installation of burner and completion of wiring must be done with front cover removed.
15. Install top cover. Align the top panel clips into the slots in the top of the side panels and slide cover forward to lock clips in place (Figure 4-12).

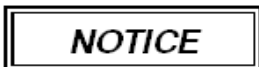

NOTICE

HydroStat 3250 Instructions - For complete installation and operation instructions, refer to the manufacturer’s instructions included with the Fuel Smart HydroStat 3250.

Figure 4-1 Rear Brackets

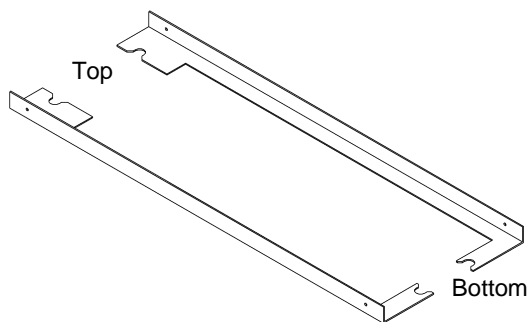

Figure 4-2 Mount Rear Brackets

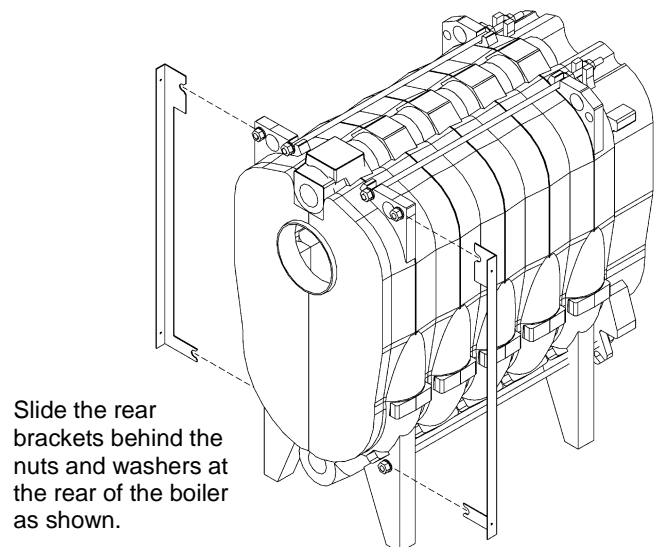

Figure 4-3 Tighten Bracket Nuts (Rear)

Tighten nuts, top and bottom, to secure the rear brackets to the boiler.

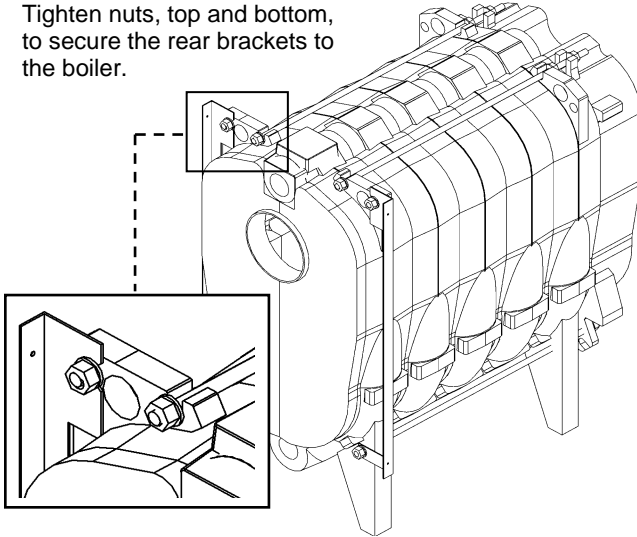

Figure 4-4 Front Brackets

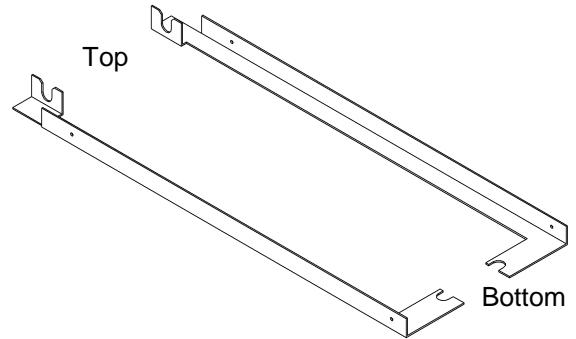

Figure 4-5 Mount Front Brackets

Slide the front brackets behind the nuts and washers at the front of the boiler.

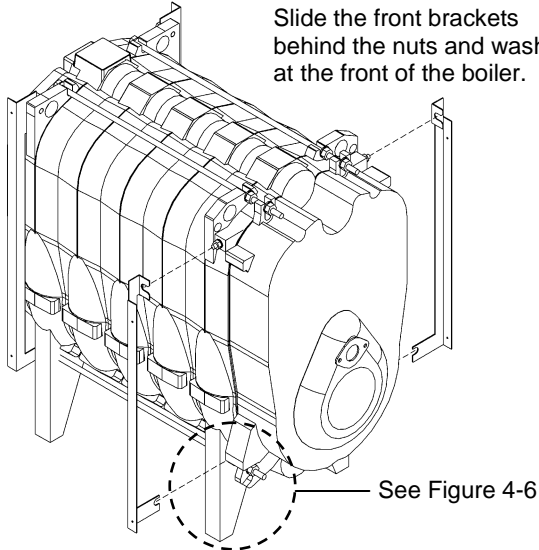

Figure 4-6 Tighten Bracket Nuts (Front)

Tighten the nuts, top and bottom, to secure the front brackets to the boiler.

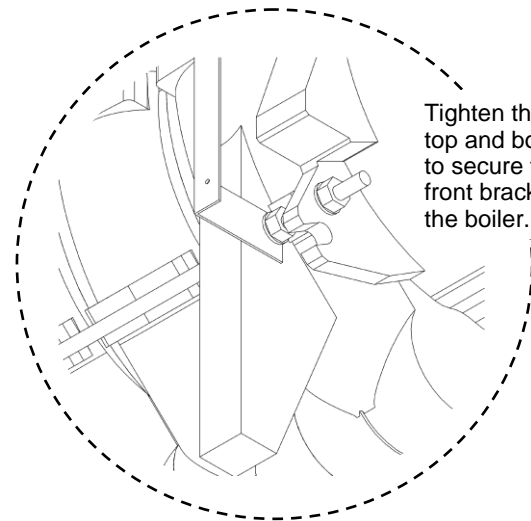

Figure 4-7 Insulate Heat Exchanger

WARNING

Before installing the insulation, read the "Handling Instructions" in Section 11.0.

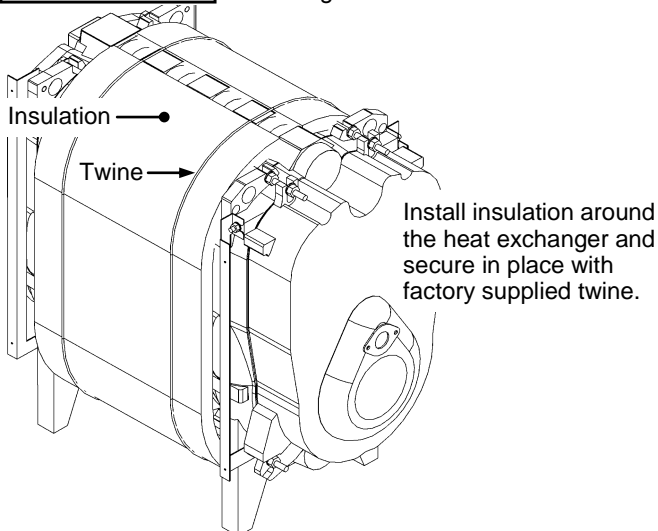

Figure 4-8 Attach Side Panels To Brackets

Remove protective plastic coating from all jacket pieces before installing.

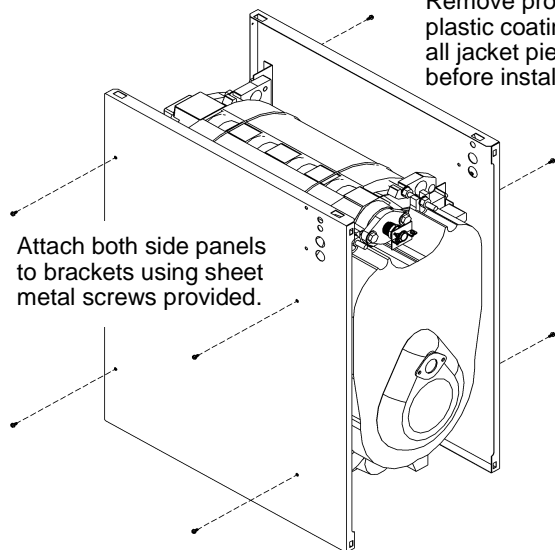

Figure 4-9 Attach HydroStat 3250 Bracket

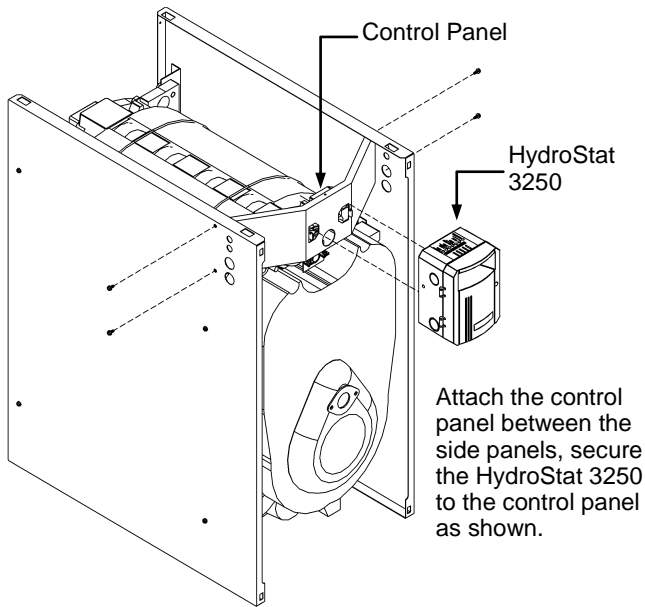

Figure 4-10 Attach Back Panels & Electro-well

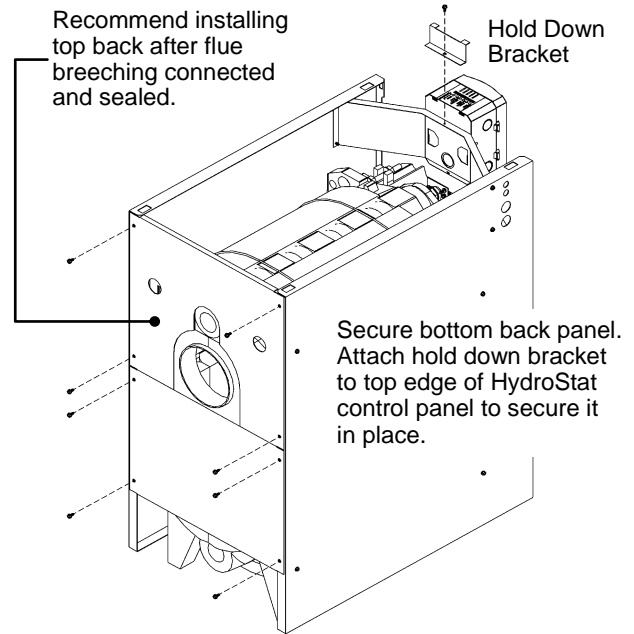

Figure 4-11 Install Ground Wire and Sensor

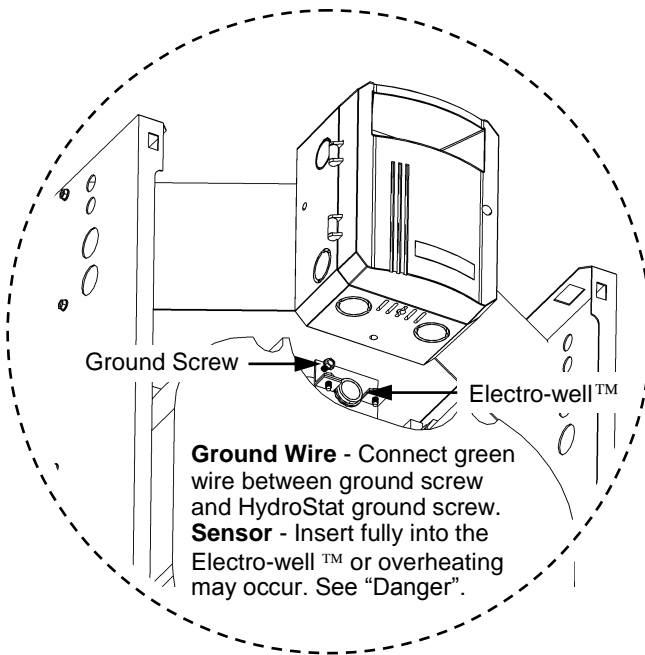
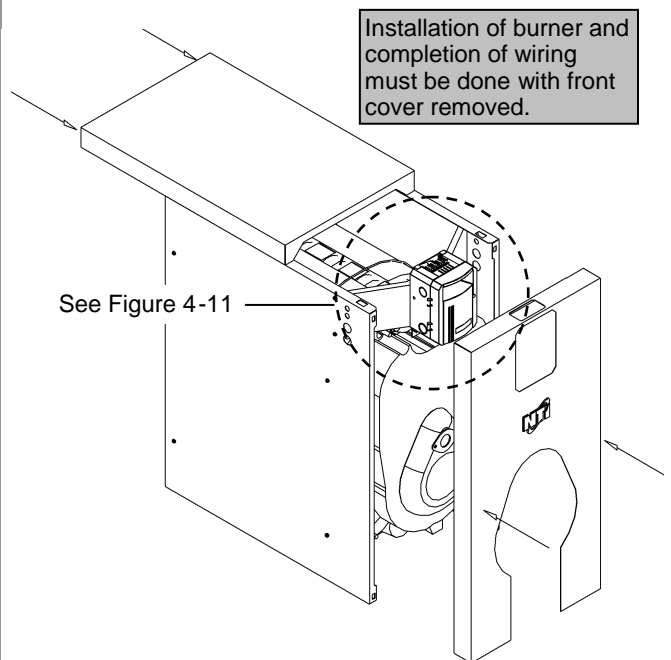

Figure 4-12 Install Top and Front Covers



Sensor - Insert the sensor fully into the Electro-well™ or the boiler may overheat resulting in fire, property damage, serious injury, or death.

Burner Installation

The Odyssey boiler is designed to work with burners described in this manual. The use of other nozzles, and/or burners, may cause unsafe operation and will void any and all responsibility by NY Thermal for the safety and reliability of the system.

The burner kit should be installed in accordance with the instructions in this manual and the burner manufacturer's instructions included with the burner. Refer to specification Tables 2-1 to 2-3 for nozzle sizes, burner settings, insertion depths, and air setting guidelines.



Fuel Oil - Odyssey boilers operate with No. 2 oil as their only approved fuel source. DO NOT USE GASOLINE, CRANKCASE DRAININGS, OR ANY OIL CONTAINING GASOLINE. Failure to follow these instructions may result in severe personal injury, property damage, or death.



Combustion Analyzer - To calibrate burner operation, use a calibrated combustion analyzer capable of measuring CO₂ and O₂ from oil burning boilers



Smoke Test - All tests must be done with the burner covers or air intakes in place to simulate normal operation.

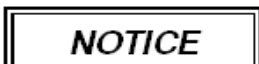

Smoke Pump - A reliable, certified smoke pump is required to correctly set up this equipment.



Avoid Condensation - Due to the high combustion efficiencies and low stack gas temperatures, great care must be taken to ensure the chimney isn't subjected to flue gas condensation. The gas temperature where the flue pipe enters the chimney must be a minimum of 240°F.

Burner Installation Procedure:

1. Burner Package:

- a. Prepare the burner in accordance with the burner manufacturers instructions included with the burner.
- b. Refer to specification Tables 2-1 to 2-3 to determine the appropriate nozzle size for the boiler output. See "Attention: Nozzle Sizes" in Section 2.0.
- c. Riello Burners (extra step required): Mount the burner gasket and burner flange to the boiler. Secure to the boiler using washers and nuts provided (Figure 4-5). Seal around the burner gasket and the blast tube ring with high temperature silicone (i.e. 83ml tube of silicone included in the burner kit).
- d. Mount prepared burner package to the boiler. Seal around burner flange with high temperature silicone.



Combustion Air Settings - Refer to Section 10.0 Installation Checklist for instruction regarding adjusting combustion air settings.

Oil Supply Tank and Oil Piping

The oil supply tank and piping should be installed in accordance with the instructions in this manual; the burner and pump manufacturer's instructions; National codes NFPA 31 (USA) or CSA B139 (Canada), and local codes.

General Installation Guidelines:

1. Install the oil supply tank as per tank manufacturer's instructions.
2. Install oil supply piping from the tank to the burner.
3. Recommend installing a low pressure-drop fuel oil filter to prevent burner nozzles plugging at low flow rates.
4. Shut-off valves should be installed to control the flow during operation and to avoid spills during servicing.
5. Oil can be fed from the supply tank by gravity (single pipe system) or by transfer pump (two-pipe lift system).
6. Refer to burner manufacturer's instructions before installing oil piping systems as some burner packages are not equipped to work with two-pipe lift systems (i.e. Riello BF5).
7. Connect oil supply piping to the fuel oil pump as per the pump manufacturer's instructions and system type.



Pipe Dope / Teflon Tape - DO NOT use on direct oil connection to the fuel pump. Failure to follow instructions may cause valve failure and dangerous operating conditions.

Figure 4-5 Burner Installation

NOTICE

Prepare the burner as per the burner manufacturer's instructions. Refer to Tables 2-1 to 2-3 for nozzle sizes, burner settings, insertion depths, air settings, and specifications.

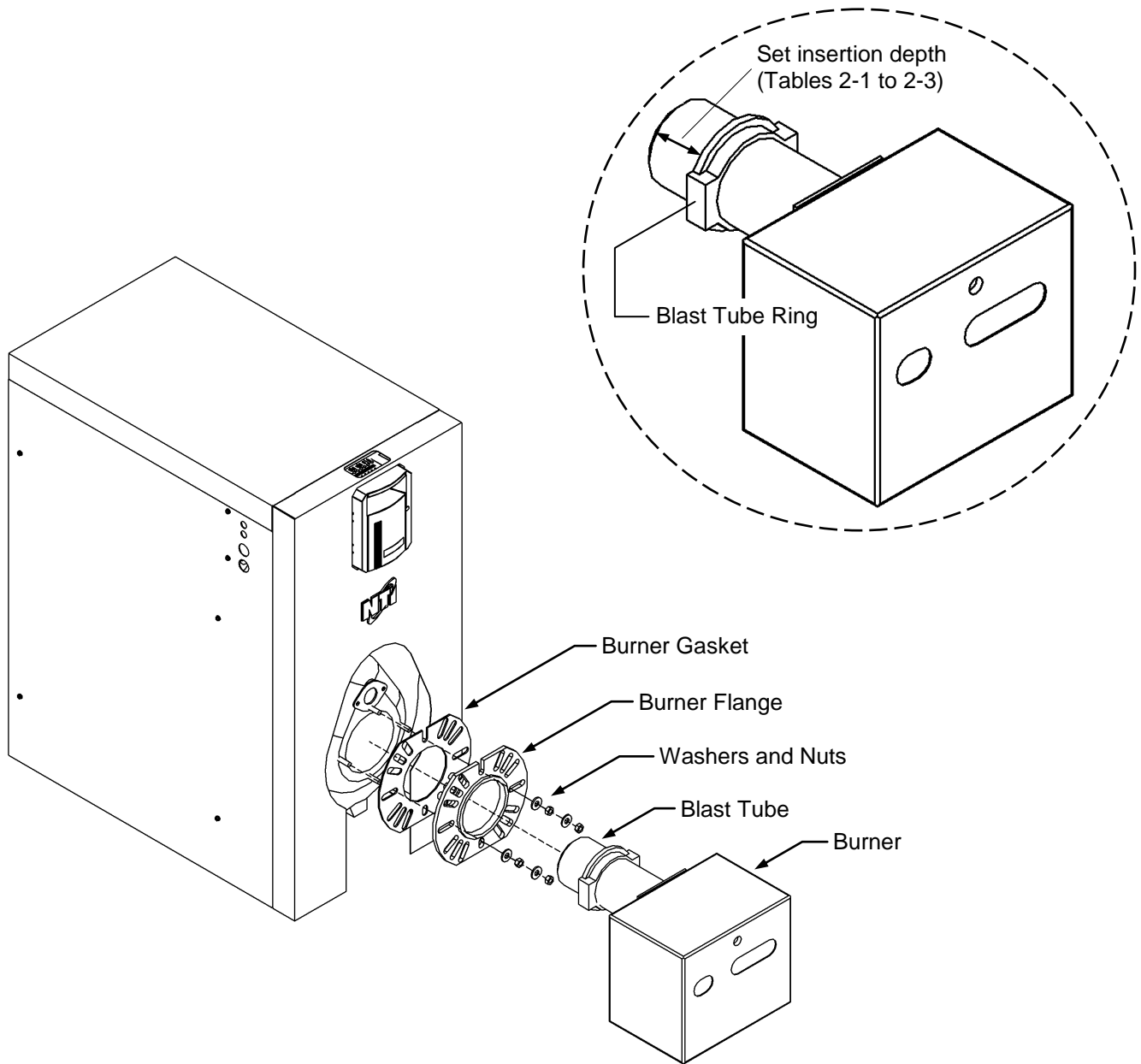

5.0 GENERAL VENTING

Natural Draft Applications

All Odyssey models are certified as Natural Draft boilers. The Natural Draft installation draws combustion air from the room and uses the stack effect and draft system to exhaust flue gases using a chimney.

Air Supply - Allowances for combustion air must be supplied to the appliance space, due to the fact that the heating appliance consumes large volumes of combustion air. In most instances, a permanent opening with an unobstructed or “free area” of 1 square inch for every 1000 BTU’s of input will provide a sufficient amount of combustion air for the boiler to operate properly. If the building is fairly new and relatively air tight, compensate for the air tightness by using a “free area” that is 15% larger than what was calculated above. Do not place the boiler in, or adjacent to, a room where an exhaust fan is operating. Refer to “Combustion Air” in Section 6.0 Natural Draft Applications for more details. Installation must comply with Standard CSA B139 (Canada) and NFPA 31 (USA).

Stack Draft - Sufficient draft by natural or mechanical means is necessary for ensuring optimal and consistent operation. The appliance should have a stack draft sufficient to support stable operation. See Draft Settings (Natural Draft).

IMPORTANT

Avoiding Condensation - Due to the high combustion efficiencies and low stack gas temperatures, great care must be taken to ensure that the chimney isn’t subjected to gas condensation. The exhaust gas temperature where the flue pipe enters the chimney must be a minimum of 240°F or condensation may occur.

Draft Regulator - A draft regulator must be used and set to regulate the draft of the boiler. Make sure that the damper is free to operate without sticking, for this will affect the boiler’s combustion system. It is important that the draft be adequate because poor draft conditions will cause poor operation and a possible hazardous condition.

IMPORTANT

Draft Settings (Natural Draft) - The Odyssey is designed to operate with a $-.03''$ w.c. draft in the flue breaching; therefore, ensure there is enough natural or mechanical draft for proper operation. Due to the design of the Odyssey it may operate at a positive over fire pressure up to $+.20$ at a $-.03$ draft.

Direct Vent Applications

Odyssey models C85-150 are also certified for direct vent applications. The Direct Vent installation uses a special venting system where exhaust gases are vented directly to the outside using a special venting system which equalizes the pressure between the air inlet and the flue outlet resulting in a balanced flue system. Refer to Section 7.0 Direct Vent Applications for more details. Installation must comply with Standard CSA B139 (Canada) and NFPA 31 (USA).

IMPORTANT

Draft Settings (Direct Vent) - Due to the design of the balanced flue system, the Odyssey will operate at a positive draft pressure and a positive over fire pressure at all times. It is designed to operate with a maximum stack draft of $0.25''$ w.c. and a maximum over fire draft of $0.33''$ w.c. when little or no wind is present. In extreme wind conditions, the maximum stack draft is $0.35''$ w.c. and the maximum over fire draft is $0.45''$ w.c.

6.0 NATURAL DRAFT APPLICATIONS

THE INSTALLATION OF THE ODYSSEY BOILER SHALL BE IN ACCORDANCE WITH THE REGULATION OF AUTHORITIES HAVING JURISDICTION AND CSA B139 (CANADA), OR NFPA 31 (USA).

Natural Draft Rules and Guidelines

1. **Acceptable Venting Material** - Use vent material approved by National Standards NFPA 31 (USA) or CSA B139 (Canada) and local codes.
2. **Venting Application** - Venting must be connected to a chimney for models operating with Natural Draft.
3. **Chimney Condition** - Inspect existing chimney before installing new boiler. Deterioration of mortar joints should be repaired prior to using.
4. **Chimney Height** - Chimney must extend 3' above the highest point where it exits the roof and 2' higher than any part of the structure within 10'.
5. **Cleaning** - Clean chimney, if required; ensure it is clear of any blockages before connecting breeching.
6. **Liner Condition** - Damaged liner or pipe should be repaired before commencing installation.
7. **Minimum Clearances** - Observe clearances to combustibles illustrated in Figure 3-1 and Table 3-1:
8. a) Double-wall vent (Type-L) 6"
9. b) Single-wall vent 9"
10. **Chimney Sizes** - Minimum chimney sizes should be used. See Table 6-1.
11. **Combustion Air** - An adequate supply of combustion air must be available to ensure proper combustion.
12. **Interlock** - If a damper is used to provide make-up air for combustion, it must be interlocked with the burner to prevent the burner starting before the damper is opened.

NOTICE

Potential Condensation - Oversized chimneys, outside masonry chimneys, and/or de-rated inputs can result in flue gases condensing in the chimney.

Combustion Air

Natural Draft boilers require an adequate amount of combustion air to sustain proper combustion and prevent flue gas leakage. The appliance's air-inlet draws combustion air from Indoors or Outdoors depending on whether there is a sufficient natural infiltration (air changes) occurring to sustain combustion. If the building is newer and relatively air tight, outdoor air should be considered. For recommended practice, refer to NFPA 31 (USA) or CSA B139 (Canada).

NOTICE

Air Circulation - The boiler shall be located so as not to interfere with proper circulation of combustion, ventilation, and dilution air.

WARNING

Make-up Air - The operation of exhaust fans, kitchen ventilation systems, clothes dryers, and fireplaces must be considered in determining the adequacy of a space to provide combustion air requirements. Failure to ensure adequate make-up air to all appliances may result in flue gas leakage, personal injury or death.

Connect Breeching & Blocked Vent Switch



WARNING

Restrictions - Use the minimum vent length and number of elbows possible to ensure flow of combustion gases are not restricted. Failure to follow instructions may result in severe personal injury or death.

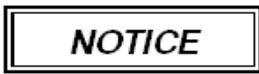

NOTICE

Blocked Vent Switch - For complete installation details, refer to the manufacturer's instructions included with the Blocked Vent Switch.

The steps for connecting breeching to a chimney are illustrated in Figure 6-1 and should be read in conjunction with the sizes specified in Table 6-1. Restricted flow can result in condensation, flue gas leakage, and/or carbon monoxide emissions.

Breeching Installation:

1. **Chimney Clearances** - Observe clearances to combustibles for breeching and chimney connections.
2. **Supports** - Install flue pipe brackets according to local codes or as needed.
3. **Breeching Sizes**- Connect breeching to the boiler flue collar. Use full size breeching when possible. Refer to Table 6-1 for minimum sizes.
4. **Potential Restrictions** - Keep breeching lengths and elbow-tee combinations to a minimum to avoid restricting the flow of combustion gases. See warning titled "Restrictions".
5. **Chimney Connections** - Use thimble or slip joint where breeching enters chimney to allow for removal for cleaning and servicing.
6. **Avoiding Obstructions** - Ensure breeching does not protrude so far into the chimney that it will cause obstruction. Avoid connecting near the bottom of chimney as blockages may result.
7. **Draft Regulator** - Ensure damper is level. See instructions included with regulator.
8. **Normal Draft Settings** - When properly installed, Odyssey models are designed to operate with $-.03''$ w.c. draft in the flue breeching. For proper operation, there must be enough natural or mechanical draft. Due to the design of the Odyssey, it may operate at a positive over fire pressure up to $+.20$ at $-.03$ draft.
9. **Draft Gauge** (if applicable) - A barometric control can be used to adjust the draft opening by installing it in the breeching. This is optional and typically only done when excessive draft conditions exist which must be relieved or to comply with applicable codes or regulations.
10. **Sealing** - Seal all vent joints.
11. **Blocked Vent Switch** - Install switch 6-8'' from boiler breeching (Canada). See manufacturer's instructions.
12. **Interlock Set-up** - Interlock burner with fan operation before start-up if using a motorized damper to supply outdoor combustion air or induced draft.

Table 6-1 Minimum Chimney Sizes

Model	Minimum Breaching Diameter	Minimum I=B=R Chimney		Minimum Chimney Height	Boiler Flue Collar Size
		Rectangular	Round		
CT80	5"	8" x 8" ¹	6"	15'	5"
CT90					
CT100					
CT120			7"	15'	
CT150					
CT180			8"	15'	
CT215					
CT230					
CT250					

Notes:

¹ 6-3/4" x 6-3/4" inside liner.

² Excessive breaching length or too many elbows and/or tee will cause restriction.

Figure 6-1 Breeching & Blocked Vent Switch

Top Back Panel - Recommend installing top back after flue breeching connected and sealed with high temperature silicone.

Secure breeching using a minimum of two screws, equally spaced. These two screws must pass through the support tabs on either side of the breeching.

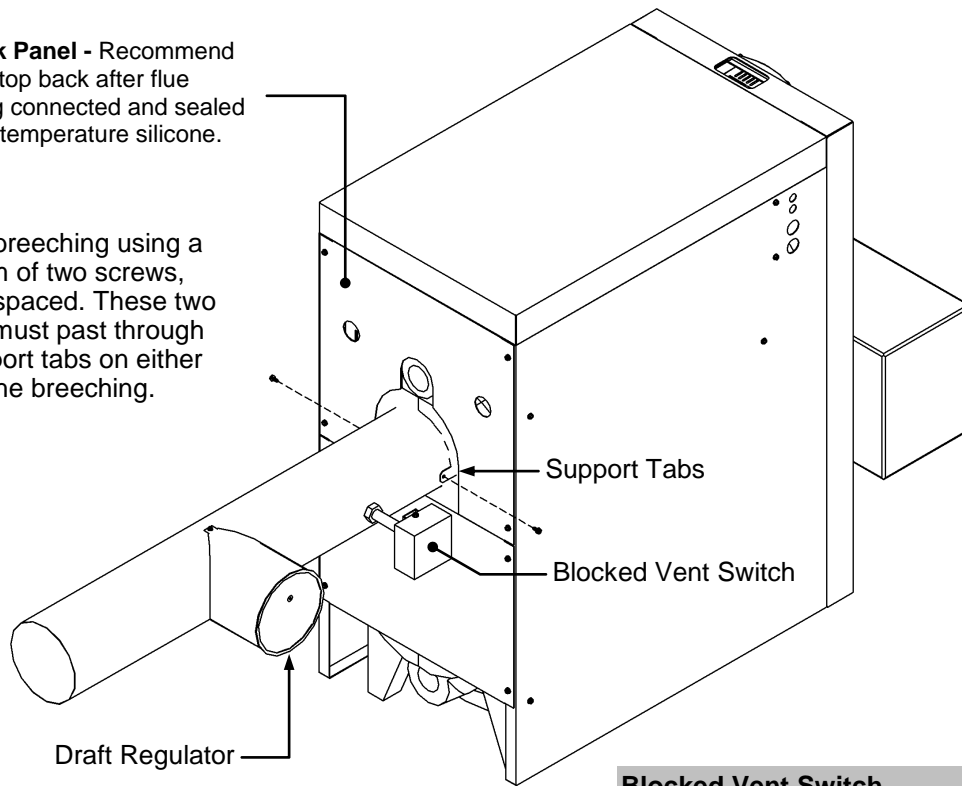

Blocked Vent Switch

Install the switch 6-8" from the boiler breeching, refer to instructions included with kit (*mandatory in Canada*).

7.0 DIRECT VENT APPLICATIONS

Direct Vent Rules and Guidelines

1. **Vent Material:** Use approved venting material. Refer to Direct Vent Termination Kit in this section.
2. **Continuous Vent:** The vent must be in one continuous piece with no joints.
3. **Balance:** Combustion air intake and vent must be installed on the same wall using the specified vent terminal to ensure the system is balanced.
4. **Prevailing Winds:** Ensure the vent is located where it will not be exposed to normal prevailing winds.
5. **Combustion Air-inlet Contamination:** Air for combustion must be drawn from an area free of dust and contaminants. Combustion air containing chemicals such as chloride, fluoride, bromine, iodine, or dust and debris will cause corrosion damage of the heat exchanger voiding your NTI warranty.
6. **Snow Level Allowance:** 24" is the recommended snow level allowance above grade or any surface that will support snow, debris, or ice required for air-inlet / vents in balanced flue systems. If living in a snowfall region, consult your local weather office for the maximum typical snowfall in your area.
Example: New Brunswick Canada - typical maximum snowfall is 19", thus the inlet must be $(12''+19'')$ = 31" above grade.
7. **Wall Flashing:** Under normal operating conditions this boiler will produce a plume of white gases, and should be taken into consideration when selecting an adequate location. A 36" [915 mm] diameter stainless, plastic, or vinyl shield can be used to flash the exterior of the residence.
8. **Flue Gas Hazard:** Position the vent termination where vapors cannot make accidental contact with people and pets, damage property, or adjacent buildings.
9. **Condensate Hazard:** Do not locate vent over public walkways, driveways or parking lots. Condensate could drip and freeze resulting in a slip hazard or damage to vehicles and machinery.
10. **Wall Thickness:** Direct Vent terminations are designed to work with any standard wall thickness. Installation guidelines for min/max wall thickness are as follows: Min.= 1" [25mm], Max.= 20" [0.5m]. Standard Vent Terminal is 8" long (p/n 81522-1) and Extended Vent Terminal is 20" long (p/n 81522-2).
11. **Venting Options:** Due to potential moisture loading (build-up) along the exterior wall, sidewall venting may not be the preferred venting option.

Direct Vent Clearances



Table 7-1 is a quick reference table that is to be read in conjunction with the numbered notes in the table, the Direct Venting Rules and Guidelines, and Figure 7-1. The instructions detailed in this section are a combination of Odyssey specific and National Code restrictions. Compliance alone doesn't ensure a satisfactory installation as good common sense must also be applied. Failure to follow these instructions may result in fire, property damage, serious injury or death.

Table 7-1 Termination Clearances Quick Reference Table

Clearances to Vent Termination	Canada ¹		USA ²	
	Min. Distance	Min. Distance	Min. Distance	Min. Distance
A Vent Terminal above grade, snow level, or an object that can support snow/ice ³	12 in.	305 mm	12 in.	305 mm
B Flue gases directed toward / causing damage to masonry, siding, or construction ⁶	x	x	x	x
C To exhaust from any other appliance ⁴	6 ft.	1.8 m	12 in.	305 mm
D From combustible materials, surrounding building openings, or property lines ⁹	6 ft.	1.8 m	-	-
E Below / adjacent operable window or building opening	6 ft.	1.8 m	4 ft.	1.2 m
F Above window, door, or building opening.	6 ft.	1.8 m	12 in.	305 mm
G To combustion air inlet from any other appliance	6 ft.	1.8 m	12 in.	305 mm
H Under a veranda, porch, deck, or balcony ⁸	6 ft.	1.8 m	-	-
I Mechanical air supply inlet to building ⁵	6 ft.	1.8 m	3 ft.	1.0 m
J Soffit, overhang, eave or parapet	2 ft.	610 mm	12 in.	305 mm
K Soffit vent; vent opening in overhang	6 ft.	1.8 m	12 in.	305 mm
L Inside corner of an L-shaped structure (including walls and fences)	3 ft.	1.0 m	3 ft.	1.0 m
M Minimum distance from the oil supply tank's vent or fill pipe (inlet)	3 ft.	1.0 m	5 ft.	1.5 m
N Above a gas meter, gas meter / regulator assembly ⁴	3 ft.	1.0 m	-	-
P Each side of center line above or below meters, regulators and vent/relief devices ⁴	6 ft.	1.8 m	-	-
Q Above or adjacent to a paved sidewalk /driveway, or parking lot ⁷	7 ft.	2.1 m	7 ft.	2.1 m
R Above a sidewalk, driveway, or parking lot on public property	x	x	x	x
S Above a sidewalk, driveway on private property between / serving both dwellings	x	x	x	x
T Into a canopy or carport	x	x	x	x
U Above, under or near exterior stairs	x	x	x	x

Notes:

- 1 - Canadian installations must comply with the current CSA B139 Natural Oil Installation Code and local codes.
- 2 - US installations must comply with current Standard NFPA 31 Installation of Oil Burning Equipment and local codes.
- 3 - 24" is the recommended snow level allowance above grade or any surface that will support snow, debris, or ice (i.e. deck). Minimum distance is 12" above grade or above snow level (which ever is greater). If living in a snowfall region, consult your local weather office for the maximum typical snowfall for your area.
- 4 - Within 3' of the vertical centerline.
- 5 - For US installations, an exhaust vent may be 3 ft above a mechanical air supply inlet if within 10 ft. [3 m] horizontally.
- 6 - The vent terminal shall not terminate where flue gases are directed toward brickwork, siding, or construction in such a manner that can cause damage from heat or condensate from the flue gases.
- 7 - Exit terminals of mechanical draft systems must maintain this minimum distance when located above or adjacent public walkways, driveways or parking lots. Flue gases cannot drip, freeze, or create a hazard.
- 8 - Only permitted if a minimum of two sides are fully open beneath.
- 9 - Vent terminal must terminate so flue gases maintain the stated clearances from combustibles, property line, and surrounding building openings.

x - Not permitted by National code(s) and/or recommended by boiler manufacturer.

Figure 7-1 Termination Clearance Quick Reference Diagram

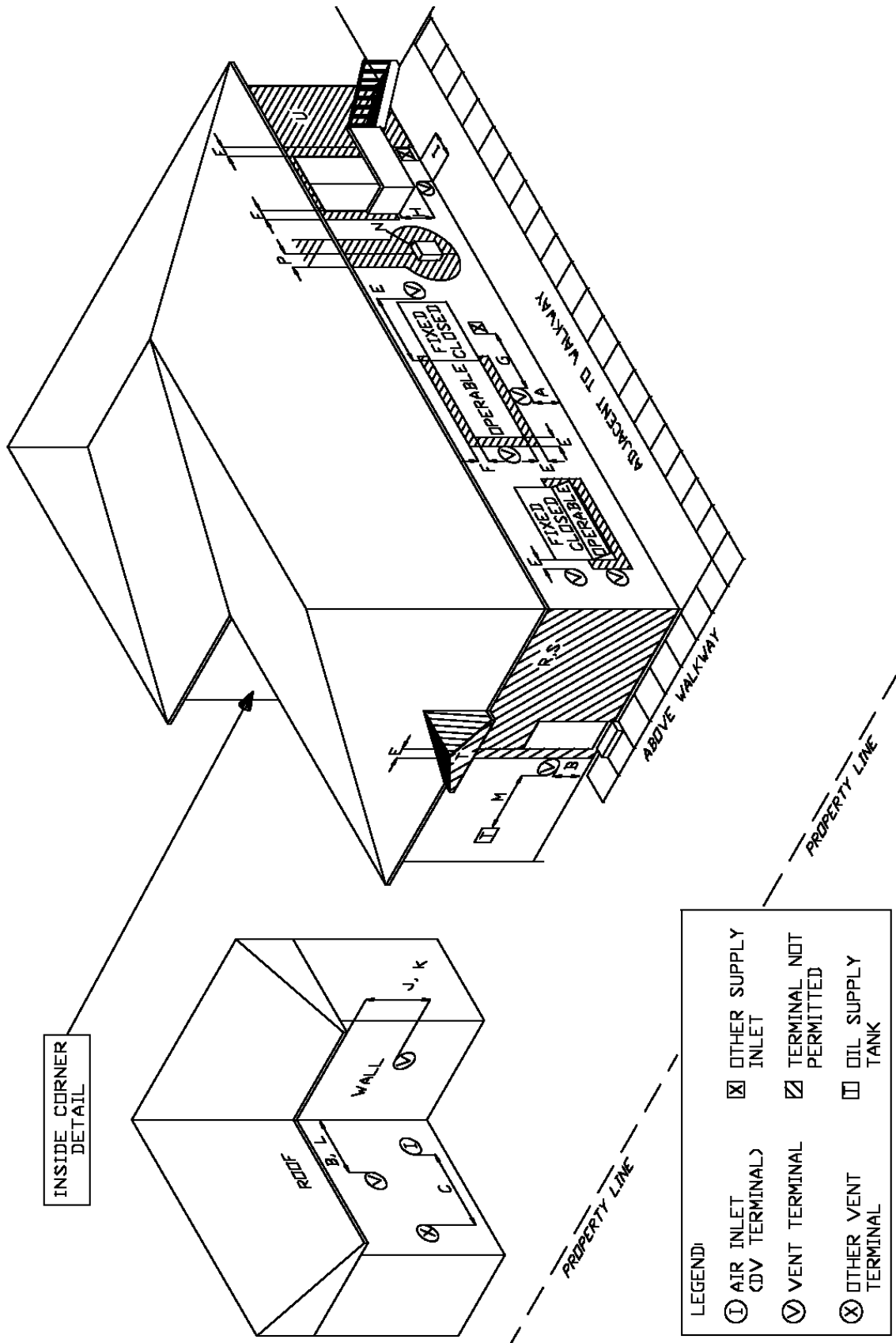

Direct Vent Termination Kit

When installed as a Direct Vent boiler the combustion air-inlet must also be piped directly to the outdoors using the methods described in this section and in accordance with the CSA B139 (Canada) or NFPA 31 (USA) and local code requirements.



Venting Options - Due to potential moisture loading (build-up) along the exterior wall, sidewall venting may not be the preferred venting option.

The majority of the balance flue components required for Direct Vent installations are included with the Burner Kit. Remaining components must be ordered separately. Refer to the components listed in Table 7-2 and illustrated in Figure 7-2.

Table 7-2 Direct Vent Components

Item	Part #	Description
Included with Direct Vent Burner Kit		
1	81764	5" to 3" Ported Adapter
2	81098	3" Insulated Flex to Pipe Adapter
3	81138	3" Flex, 10' long ³
4	81625	Hose Clamps, 3" (2)
Direct Vent Terminal¹		
5	81522-1	Direct Vent Terminal, 8"
Insulated Flex^{1,3}		
6	81109	5' Insulated Flex
	81097	10' Insulated Flex
	81110	15' Insulated Flex
	81111	20' Insulated Flex
Optional Components²		
-	81522-2	Extended Direct Vent Terminal, 20"
-	81453	Silicone, High Temp., 302 (83ml)
-	81847	3" Direct Vent 90° Elbow
-	81633	Adapter 3" x 20' Flex Aluminum
-	83026	5" to 3" 90° Elbow Ported

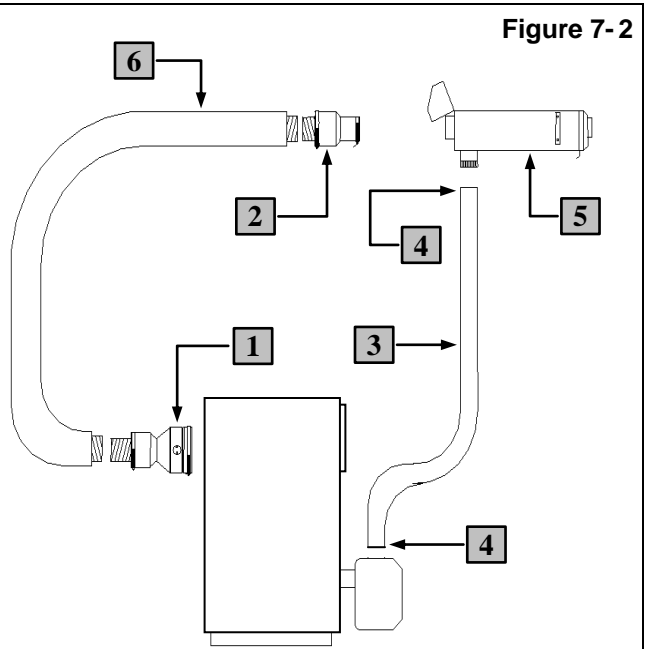

Components required for Direct Vent installation:

- Items 1-4 included with the boiler's DV Burner Kit.
- Items 5-6 must be ordered separately.

Notes:

- ¹ Required for Direct Vent installation but not included with boiler package; therefore, must be ordered separately.
- ² Optional components available from NTI. Must be ordered separately.
- ³ The vent and air intake maximum length is 20' (6m).

Direct Vent Installation Instructions

NOTICE

Vent Location - Under normal operating conditions, the boiler will vent plumes of white flue gases; therefore, code restrictions and potential hazards associated with thru-wall installations should be considered before selecting a location for the Direct Vent terminal.

To install the Direct Vent Termination Kit for the balanced flue system, complete the steps listed below in sequence. Note there are two parts to the install, outside prep work and inside connections:

PART A: Outside

- Vent Location** - Select a suitable location for the vent terminal. It is highly recommended that the vent terminal be located where it will not be exposed to normal prevailing winds. See NFPA 31 (USA), CSA B139 (Canada) for code clearances.
- Exterior Surface** - Ensure that the outside wall surface is flat and meets the installation clearances. See Table 7-1 and Figure 7-1.
- Vent Hole** - Cut a rectangular hole, 5.5" wide, and 6.5" in height in the exterior wall.
- Orientation** - Insert the vent terminal through the rectangular hole into the building so that the 3" diameter hole for the air intake is facing downward. See Figure 7-3.
- Slope** - When installed correctly, the vent terminal pipe should point slightly uphill in order to drain water to the outside. If it is not sloped to the outside, flue gases will condense and drain back into the boiler.
- Mounting Tabs** - Secure the mounting tabs on either side of the vent terminal to the outside of the structure using 4 x #10 stainless steel screws (field supplied).
- Sealing** - Using a suitable silicone sealant, seal the gap between the structure and the vent terminal.

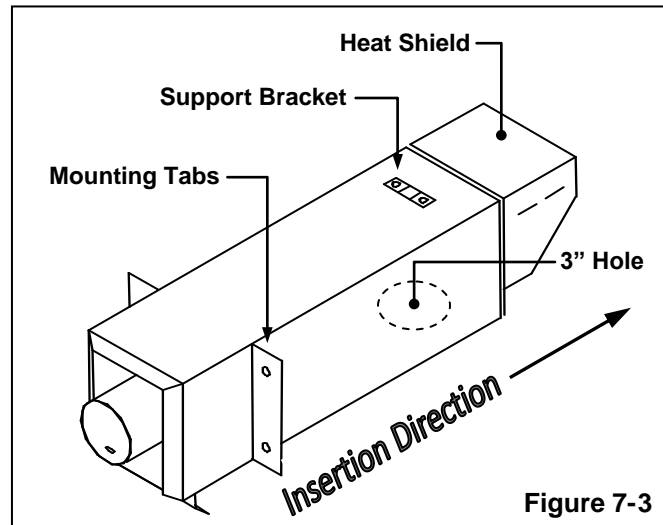

Figure 7-3

PART B: Inside

- Bend Bracket Support** - Using a screwdriver, bend up the support bracket located on the top of the unit as shown in Figure 7-4.
- Support** - Support the back end of the vent terminal by connecting the support bracket to a joist, or other solid structure, by means of metal strapping or wire.
- Air Inlet Connections** - Using the screws provided, attach the air inlet connection flange to the bottom of the vent terminal. Figure 7-4.
- Heat Shield** - The back of the vent terminal is equipped with a flexible heat shield, bend the flaps to the side, and then bend the heat shield up, and out of the way as shown in Figure 7-5.
- Silicone** - Seal the space between the vent terminal and the structure. Refer to "Sealing" section for more detailed instructions.
- Flex Piping** - Install air inlet flex piping (3" flex 10') over air inlet connection (Figure 7-5). Secure with a 3" gear clamp included in the burner kit. Connect other end of flex piping directly to the Riello burner (or increaser if using a Beckett burner). See Figure 7-7.
- Insulated Flex** - The boiler can now be connected to the vent terminal with the help of insulated flex piping. The flex piping is available in lengths of 5 ft, 10 ft, 15ft, and 20 ft. Ensure the flex piping is long enough to form long radius bends (no smaller than 1 ft in radius). If the flex is too long, it can be cut with a hacksaw.
- Direct Vent** - Assemble Direct Vent as detailed in following section titled "Sealing". Use only high temperature silicone provided or referenced in instructions.

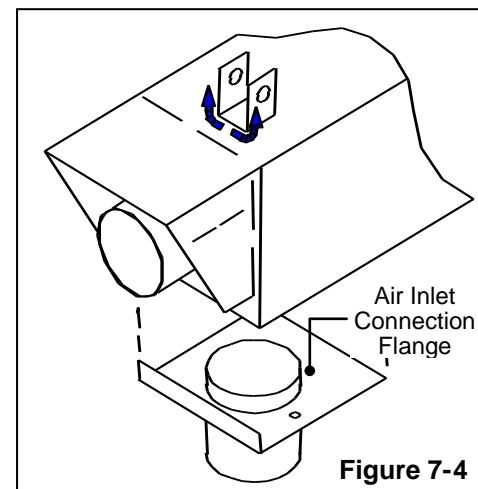

Figure 7-4

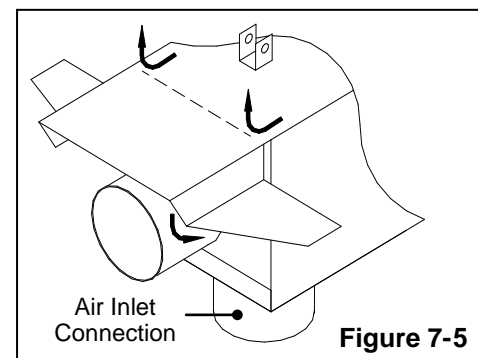
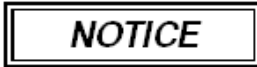

Figure 7-5

Sealing



Proper Sealing - This Balanced Flue system will leak if the following sealing procedures are not followed. It's easier to seal the entire system properly the first time than return at a later date and have to remove the connections to reseal it.



The adapters are multi-start, left hand thread, with one thread twice the width of the others. Therefore, care must be taken to ensure that the correct threads are engaged before tightening in a counter clockwise direction.

Clearances to Combustibles - The vent must have 9" clearance to combustible within 36" of the appliance breach. The remaining section of the vent to the terminal can have a minimum of 1" clearance. The terminal is rated for 0" clearance.

Recommended Sealing Method - Because the balanced flue system operates with a positive pressure in the exhaust at all times, the sealing has to be done properly to prevent leaks at the joints. The type of sealant used throughout this installation is critical to the operation of the balanced flue system. A tube of high temperature silicone is provided with the installation kit (#81453). This tube should be sufficient for the whole installation, but if more sealant is needed buy one of the following: GE 106, Dow Corning 736 Heat Resistant Sealant, Perimeter 248 High Temp or RTV Silicone Gasket.



It's the installer's responsibility to ensure that combustion products do not enter the home.

To obtain a good seal between the Vent Terminal and the building wall, follow Steps "A" through "J" illustrated in Figure 7-6:

PART 1: Boiler

- A. Seal the 5" smoke collar to the smoke hood on the boiler with the high temperature silicone. Inspect all boiler openings (sight door, burner connection, pipe joints, Etc) during initial operation, to verify there are no leaks.



Flex Pipe - Make sure that it's long enough to form long radius bends (no smaller than 1 ft in radius). If the flex is too long, it can be cut with a hacksaw.

Flex Adapter Collar - It is recommended to remove the collar on the 81098 & 81112 flex adapters that secure the insulation and outer foil of the flex pipe. This can be accomplished by removing the pop rivet at the base of the collar, and backing off the gear clamp completely. After removing the collar, you will get an unobstructed view of the pipe joint. To reinstall, put the collar back into place and install a #8 x 1/2" screw in rivet hole, and re-thread the gear clamp.

PART 2: Flex Pipe

- B. Pull the outer foil sheathing and insulation back to give an unobstructed view of the pipe joints. Put 1 bead of silicone on both inside ends of the insulated flex pipe, approximately 1" wide and 1/2" from the end. Put 1 bead of silicone on both outside ends of 81098 & 81112 connectors, approximately 1" wide and 1" from the bottom of the threads. Screw in part number 81089 & 81112 adapters into the insulated flex and pull the insulation and the outside flex over the collar and tighten the gear clamp.
- C. Apply a wide bead on top of the flex joint.
- D. Reinstall the collars on the vent connectors using a #8 x 1/2" screw in rivet hole, and re-thread the gear clamp
- E. Apply silicone between the vertical overlap joint of the 5" to 3" adapter.
- F. Apply silicone on inside surface of the 5" to 3" adapter.
- G. Apply silicone on outside surface of the boiler cast collar, and slide 5" to 3" adapter over the smoke hood and tighten the gear clamp.
- H. Perform steps D-G to install the 3" adapter #81098 over the 3" vent terminal, and tighten gear clamp.
- I. Fold the vent terminal heat shield flaps back into position.
- J. Refer to Figure 7-7 for an illustration of a typical balanced flue installation for an Odyssey boiler (CT90-120).

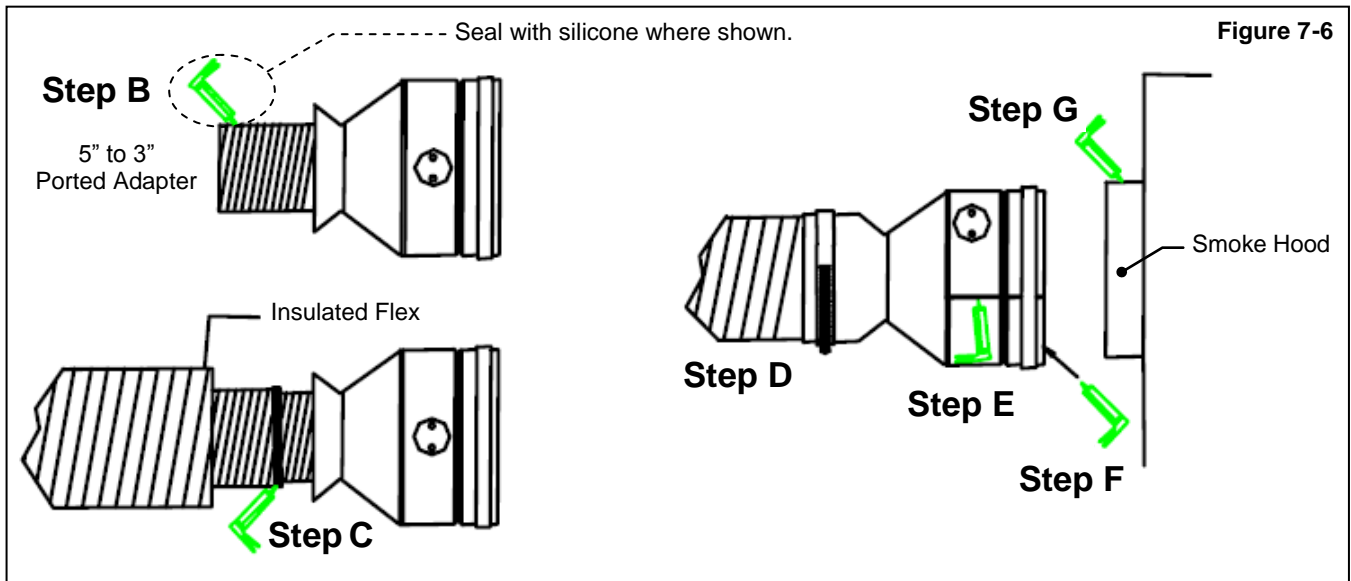

⚠ WARNING

Important Warning - It is the responsibility of the installing contractor to ensure that:

1. The boiler and venting system are totally sealed from products of combustion.
2. The homeowner is advised of their responsibility of keeping the vent terminal clear of snow and ice.
3. That the home is equipped with a carbon monoxide detector.

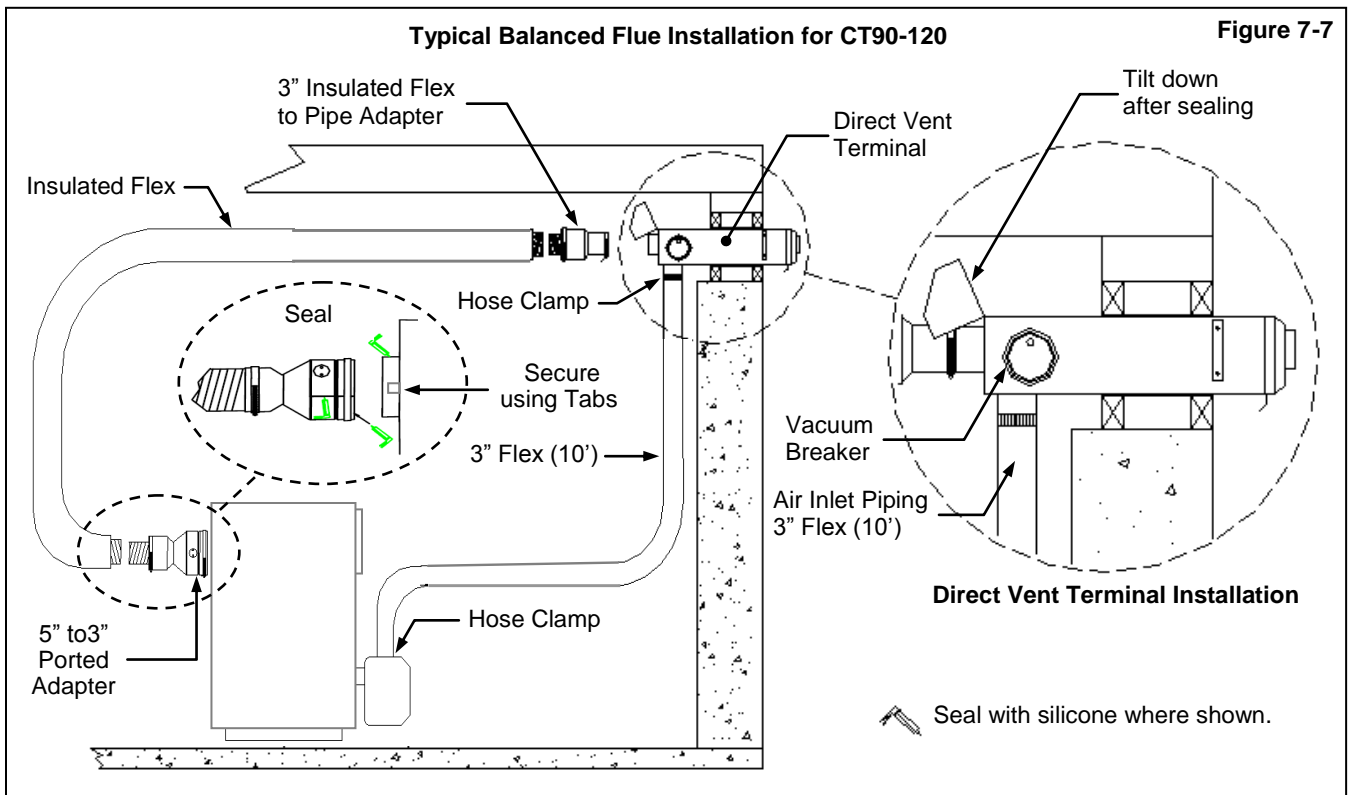

8.0 BOILER PIPING

Boiler Water

Pressure - Odyssey boilers are intended to solely for use in pressurized closed-loop heating systems operating with a “fill pressure” between 12-15 psi at the boiler outlet and a Relief Valve pressure of 30 psi (maximum working pressure of the boiler).

Oxygen Elimination - The Odyssey boiler is designed to operate in a pressurized closed-loop heating system, free of air and other impurities. To avoid the presence of oxygen, ensure all of the air is removed from the system during commissioning via strategically placed, adequately sized air-removal devices located throughout the heating system and the boiler piping (Figure 8-1). Immediately repair any leaks in the system plumbing to avoid the addition of make-up water; make-up water provides a source of oxygen and minerals that may lead to heat exchanger failure, poor performance, unnecessary wear of system components, and premature failure.

NOTICE

Closed System - The Odyssey is not approved for operation in an “open system”, thus it cannot be used for direct potable water heating or process heating of any kind.

Antifreeze - If using antifreeze, use an inhibited propylene glycol specifically designed for hydronic systems. NTI recommends against exceeding 35% concentration of glycol.

Near Boiler Plumbing

Install boiler piping for central heat and domestic hot water as shown in Figure 8-1.

Gauges - The temperature and pressure gauges (Ttridicator) is factory supplied and must be field installed in the front of the boiler or on the coil plate.

Relief Valve - A 30 psi relief valve is factory supplied and must be field installed.

Piping - The closed loop piping system must be in accordance with the central heat piping illustration. All piping joints must be secure and water tight or the boiler warranty is void.

Water Supply - Pressure regulating “fill valve” (12-15 psi) and back flow preventer are required (Figure 8-1).

Boiler Venting - Hot waters boilers are designed to operate with the airless water in the system. The NY Thermal boilers are designed with a built-in air trap, to purge air at the ¾” relief valve nipple. An air vent must be installed here or the boiler warranty is void.

WARNING

Low Water Cut Off (LWCO) - To take advantage of the HydroStat’s LWCO feature, the Odyssey is equipped with a special immersion well call the Electro-well™. Failure to use the Electro-well™ provided with the boiler will over-ride the LWCO feature and allow the boiler to operation during low water conditions which may result in over heating, fire, serious injury, or death.

NOTICE

Verify LWCO is Active - Ensure the LWCO active light is illuminated on the HydrStat 3250 when using the Electro-well™. If the indicator light is not illuminated than the LWCO feature is not active. Refer to manufacturer’s instructions included with the HydroStat 3250.

IMPORTANT

Removing Air - Do not fill the boiler with water until you are ready to fire the burner. Once filled with water, bring the boiler up to temperature and remove the air.

Removing Air from the Boiler:

1. Open automatic air vent 1 turn.
2. Bleed air from system. Starting at the lowest point in the building, open air vents one at a time and leave them open until water comes out. Close all air vents, except the automatic air vent.
3. Refill to correct pressure, 12-15 psi.

Figure 8-1 Near Boiler Piping
Central Heat

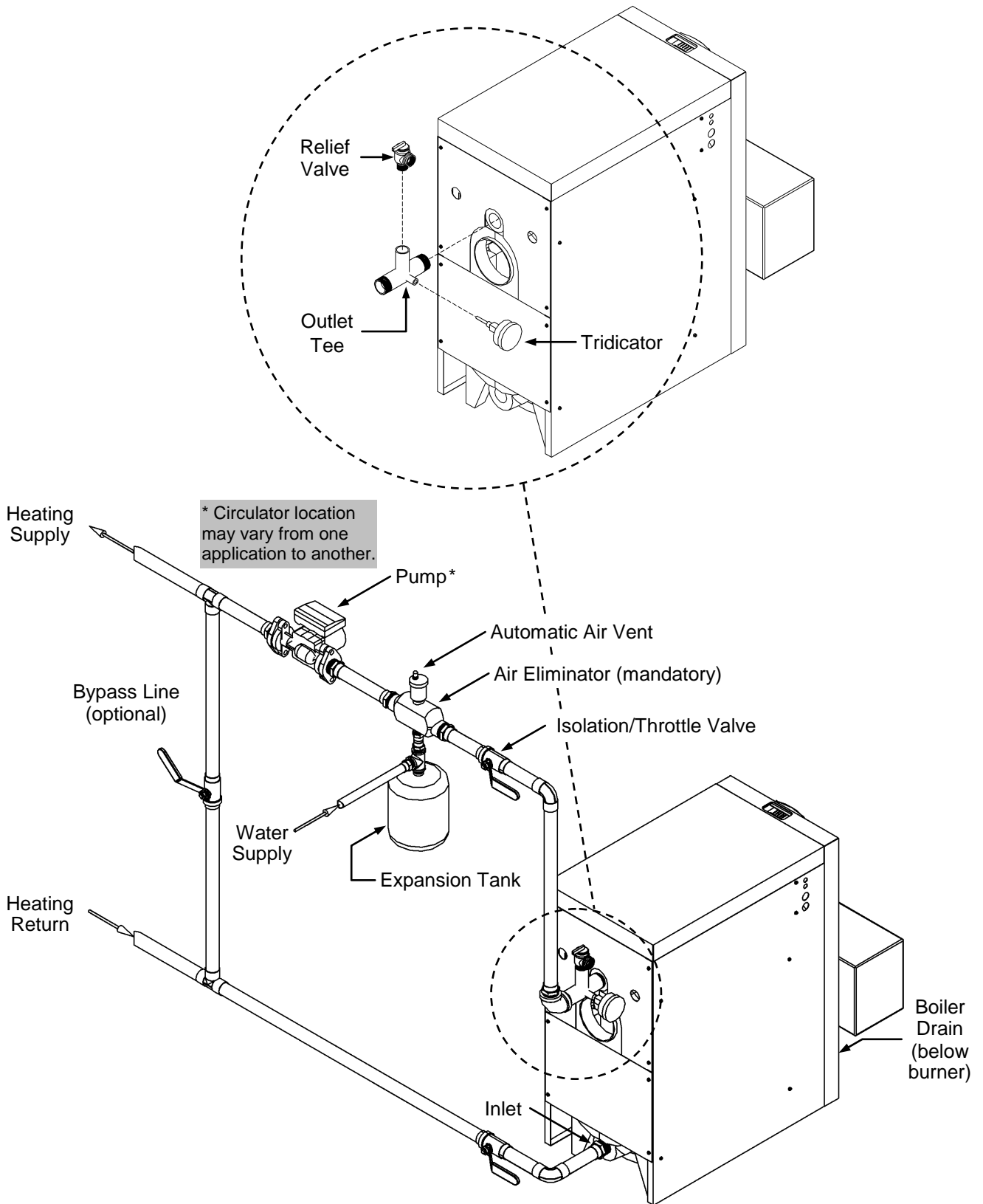

9.0 FIELD WIRING

All wiring and electrical grounding must be in accordance with local codes and the applicable National Electrical Code, NFPA 70 (USA) or CSA C22.2 (Canada). Ensure that the wiring complies with this manual.



Avoid Shocks - To Avoid Electrical Shock, turn off electrical power to the boiler prior to opening any electrical box within the unit. Ensure the power remains off while any wiring connections are being made. Failure to follow these instructions may result in component failure, serious injury or death.



Wire Protection - When passing any wiring through the casing of any component or electrical box, the installer must use wire grommets suitable for securing the wiring and preventing chafing. Failure to follow instructions may result in component failure, serious injury or death.



Burner Primary Safety - Blocked Vent Switch and any other limit device must break power to the burner primary (B1). Failure to follow these instructions may result in serious injury or death.



Labeling - Label all wires prior to disconnecting them when servicing controls. Wiring errors can cause improper and dangerous operation. Failure to follow instructions may result in property damage or personal injury.

Connection	Description
T-T	Heat Demand Input (Dry Contact) - from heating thermostat or zone controller. Contact closure indicates to the controller that there is a heating demand, controller will apply Thermal Targeting
WWSD	Outdoor Temperature Sensor (Factory Supplied) – Connecting the OD Sensor to WWSD and C enables the Warm Weather Shutdown feature of the controller. Control will not respond to T-T demands when the outdoor temperature is above the WWSD setting.
C	
OR	

Table 9-2 Electrical Field Connections - Line Voltage

Connection	Description
L1	Power Supply Hot – 120VAC input for the controller. Installation codes require the installation of a service switch to break line voltage to the appliance. Power supply must be protected with 15 Amp circuit breaker or fuse.
L2	Power Supply Neutral – Location for connecting the Neutral of the power supply.
C2	Circulator Neutral – Location for connecting the Neutral to the circulator.
C1	Circulator Hot – 120VAC output to circulator (5.8 FLA max.)
B1	Burner Hot – 120VAC output to burner (7.4 FLA max.). Additional safety limits, i.e. LWCO and/or Blocked Vent Switch, must be installed in series with this circuit. B1 is the Burner Primary.
B2	Burner Neutral – Location for connecting the Neutral to the burner.
ZC	Priority Zone Output (120VAC) – Power supply for priority zone, power is always present at ZC unless the LO TEMP temperature is not attained.
ZR	Priority Zone Input (120VAC) – When power is applied to ZR from ZC, via a contact closure of an Indirect Tank Thermostat, when Zone/Indirect Switch is set to “I”, the control overrides Thermal Targeting and Outdoor Reset functions, and operates to the HI TEMP setting. When Zone/Indirect Switch is set to “Z”, the control interprets the call as an end switch from Priority Zone relay, and operates as a central heat demand performing Thermal Targeting or Outdoor Reset functions.

Figure 9-1 Odyssey Wiring Diagram

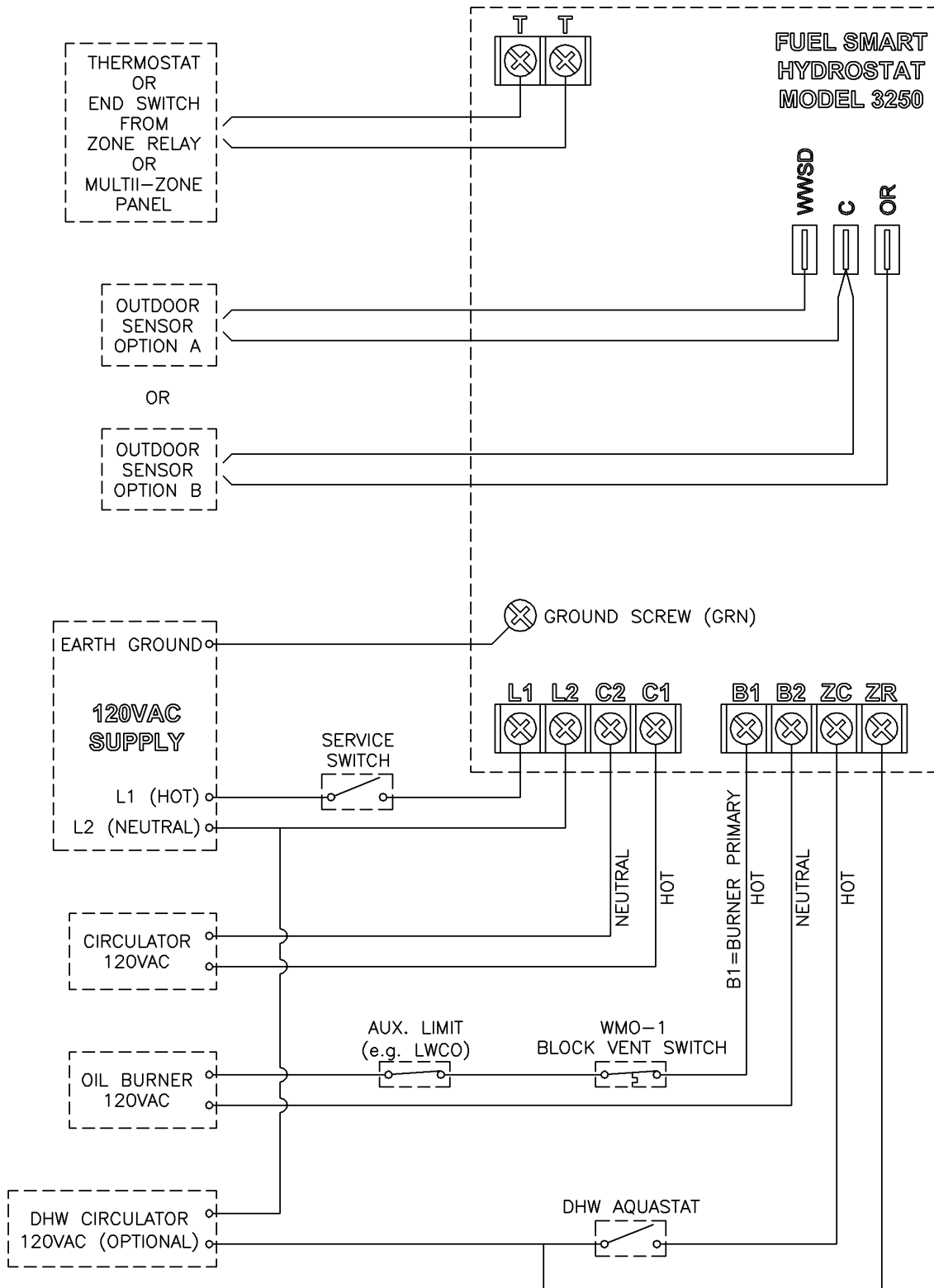

WARNING **Burner Primary Safety** - The Blocked Vent Switch and any other limit device must break power to the burner primary (B1). Failure to follow these instructions may result in serious injury or death.

Fuel Smart HydroStat Model 3250

The Fuel Smart HydroStat 3250-Plus is manufactured by HydroLevel Company. It is a Temperature Limit and Reset Control for oil and gas fired boilers. It meets the September 2012 requirements for “Automatic Means” of adjusting boiler temperature. The HydroStat provides only temperature and reset functionality when installed on a standard immersion well used on Caprice models.

Temperature Limit – In lieu of the HydroStat 3250 the Honeywell Aquastat models L7248A, L7224U or L8148A can be used on Odyssey boilers.



Low Water Cut Off (LWCO) - To take advantage of the HydroStat’s LWCO feature, the Odyssey is equipped with a special immersion well call the Electro-well™. Failure to use the Electro-well™ provided with the boiler will over-ride the LWCO feature and allow the boiler to operation during low water conditions which may result in over heating, fire, serious injury, or death.

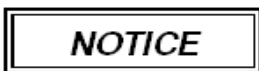

Verify LWCO is Active - Ensure the LWCO active light is illuminated on the HydroStat 3250 when using the Electro-well™. If the indicator light is not illuminated than the LWCO feature is not active. Refer to manufacturer’s instructions included with the HydroStat 3250.



Infloor Radiant Heating Applications - When the heating system incorporates low temperature radiant heating, external mixing controls must be used to regulate the temperature. Failure to follow these instructions may result in property damage.

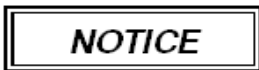

HydroStat 3250 - For complete installation details and instructions on controls operation, refer to the manufacturer’s instructions included with the Fuel Smart HydroStat 3250.

Table 9-3 HydroStat 3250 Control Settings

Parameter	Default	Recommended Settings
HI TEMP	190°F	140-210°F
LO TEMP	OFF	OFF
ECONOMY (<i>Thermal Targeting</i>)	1	See <i>Thermal Targeting Method</i>
ECONOMY (<i>Outdoor Reset</i>)	1.00	See <i>Outdoor Reset Method</i>
Thermal Pre-Purge	OFF	ON
Warm Weather Shutdown (WWSD)	70°F	70°F
Zone/Indirect Switch	I	See <i>Zone/Indirect Switch</i>
General Notes: 1 – LO TEMP must be set at least 10°F below the HI TEMP. 2 - Set HI TEMP according to temperature demands of the heating system, high for finned-tube baseboard or low for infloor radiant.		

Control Settings

▪ HI TEMP:

- Setting establishes the maximum boiler operating temperature for safety (burner will not operate above this setting).
- Do not set greater than 210°F.
- With Zone/Indirect Switch set to “I”, boiler operates to the HI TEMP setting during a ZC-ZR demand (DHW- Indirect Tank)

LO TEMP:

- Minimum permissible boiler temperature, burner will fire without demand when temperature drops below the LO TEMP setting.
- Controller inhibits circulator operation (120V outputs at C1 and ZC are deactivated) until the temperature exceeds the LO TEMP setting.
- Set LO TEMP at least 10°F below HI TEMP setting.
- See “Setting the Low Limit” in the Hydrolevel installation instructions included with the HydroStat 3250.

ECONOMY

- Establishes the Boost Interval and Subtractive Differential settings for Thermal Targeting; see *Thermal Targeting Method* below.
- Establishes the Reset Ratio setting for Outdoor Reset operation: see *Outdoor Reset Method* below
- The higher the setting the greater the reduction in boiler operating temperature and fuel consumption.

Thermal Pre-Purge

- When set to ON, the control will purge the boiler temperature down to 135°F at the start of any thermostat call before firing the burner. Display indicates "Pur" when control is in Thermal Pre-Purge mode.
- To set Thermal Pre-Purge ON, perform the following steps:
 1. Turn the LO TEMP dial to “Pro”.
 2. Turn the HI TEMP dial to select feature 1.
 3. Push the Test/Settings Button to turn Thermal Pre-Purge ON or OFF.
 4. Reset LO TEMP and HI TEMP settings to desired temperatures.

Zone / Indirect Switch

Determines the function of the ZC-ZR input.

- Switch = "Z" (Zone) – ZC-ZR demands are treated as central heat/thermostat demands; Thermal Targeting and Pre-purge features are active.
- Switch = "I" (Indirect) – ZC-ZR demands are treated as DHW demands; Thermal Targeting and Pre-purge features are overridden, boiler operates to the HI TEMP Setting.
- If ZC-ZR input is not used (i.e. nothing is wired to it), the Zone/Indirect Switch setting is irrelevant.

IMPORTANT

Outdoor Sensor - The outdoor sensor (p/n: 83604) is included in the burner kit, it must be connected to the Fuel Smart HydroStat Control 3250 prior to setting up the control.

Warm Weather Shutdown (WWSD)

The Warm Weather Shutdown feature prevents the boiler from providing central heating when the outside temperature reaches a level that you select. The boiler will still operate to satisfy a call for domestic hot water.

- Available settings range from OFF or 40°- 70°F (factory default = 70°F).
- To adjust the WWSD setting, press and hold the Test/Setting Button and simultaneously adjust the Economy dial to the desired setting.
- To turn the feature off (allows space heating regardless of outdoor temperature), press and hold the Test/Setting Button and simultaneously turn the Economy dial fully counter-clockwise. Release the Test/Setting Button.

Inferring Heat Load (“Automatic Means” of Adjusting Boiler Temperature)

The HydroStat control incorporates two (2) options for Inferring Heat Load:

- 1) Thermal Targeting Method – default method
- 2) Outdoor Reset Method – method used when outdoor sensor is connected to OR and C

1) Thermal Targeting Method:

- Default method for satisfying central heat demands.
- For the duration of a central heat demand, the target temperature is boosted by 10°F every Boost Interval.
- For each new central heat demand, the control reduces the target temperature established in the previous cycle by 5°F.
- For every 30 minutes of no central heat demand, the control will reduce the target temperature by 5°F.
- The Subtractive Differential establishes how much the boiler temperature must drop below the target temperature, before the burner will fire for a central heat demand.
- The Economy Feature setting determines the Boost Interval and Subtractive Differential values; see Table 9-4.
- Thermal Targeting is overridden when Economy Feature is set to OFF, i.e. central heat demands operate to the HI TEMP setting.
- A central heat demand is activated by a T-T demand or ZC-ZR demand when the Zone/Indirect switch is set to "Z".
- With an Outdoor Sensor connected to WWSD and C, the control will perform Warm Weather Shutdown and Thermal Targeting.
- With an Outdoor Sensor connected to OR and C, the control will override Thermal Targeting and instead function as an Outdoor Reset control with Warm Weather Shutdown – see 2) *Outdoor Reset Method* below.

Table 9-4 Economy Feature Setting (for Thermal Targeting)

Setting ¹	Subtractive Differential	Boost Interval	Recommended Settings and Applications
OFF	10°F	N/A	Disables Thermal Targeting. Applications where a boiler must fire to the High Limit (HI TEMP setting)
LO	20°F	10 min	Lowest level of fuel savings. Use only if other settings can't meet the demand load.
1	20°F	15 min	1 zone heating system.
2	20°F	20 min	2 zone heating system.
3	20°F	25 min	3 zone heating system.
4	20°F	30 min	4 zone heating system.
5	20°F	35 min	5 zone heating system.
HI	20°F	40 min	Maximum efficiency. Highest level of fuel savings.

Notes:

1 - Do not include Indirect Water Heaters in the number of heating zones.

2) Outdoor Reset Method:

- Automatically active when the Outdoor Sensor is connected to the OR and C spade connects on the Fuel Smart HydroStat.
- Outdoor Reset overrides Thermal Targeting Method.
- The Reset Ratio setting dictates the influence the outdoor temperature has on the boiler target temperature during a central heat demand. The boiler target temperature increases by the Reset Ratio setting for every 1°F decrease in outdoor temperature. Inversely, the boiler target temperature decreases by the Reset Ratio setting for every 1°F increase in outdoor temperature.
- The Reset Ratio is set using the Economy Feature Dial. Use Table 9-5 to aid in setting the Reset Ratio for your application.
 - *Example: if the outdoor design temperature is 0°F (typical for the Northeast), and the design heating water is 180°F (typical for baseboard heating), then set Reset Ratio = 1.50.*
- The display will toggle between boiler temperature (8 seconds) and outdoor temperature (2 seconds).
- To check the current target temperature, press the Test/Settings button in 4 short intervals.
- If the Outdoor Sensor becomes damaged or disconnected, the control will automatically revert back to the Thermal Targeting Method. The display will no longer toggle outdoor temperature.

Table 9-5 Economy Feature Setting (for Outdoor Reset)

		Reset Ratio Chart																																		
		200	195	190	185	180	175	170	165	160	155	150	145	140	-40	-35	-30	-25	-20	-15	-10	-5	0	5	10	15	20	25	30	35	40	45				
Boiler Temperature of	200	1.25	1.25	1.25	1.25	1.50	1.50	1.50	1.50	1.75	1.75	2.00	2.00	2.25	2.50	2.50	2.50	2.50	2.50	2.50	2.50	2.50	2.50	2.50	2.50	2.50	2.50	2.50	2.50	2.50	2.50	2.50	2.50	2.50		
	195	1.00	1.25	1.25	1.25	1.25	1.50	1.50	1.50	1.50	1.75	1.75	2.00	2.25	2.25	2.50	2.50	2.50	2.50	2.50	2.50	2.50	2.50	2.50	2.50	2.50	2.50	2.50	2.50	2.50	2.50	2.50	2.50	2.50	2.50	
	190	1.00	1.00	1.25	1.25	1.25	1.50	1.50	1.50	1.50	1.75	1.75	2.00	2.00	2.25	2.50	2.50	2.50	2.50	2.50	2.50	2.50	2.50	2.50	2.50	2.50	2.50	2.50	2.50	2.50	2.50	2.50	2.50	2.50	2.50	
	185	1.00	1.00	1.00	1.25	1.25	1.25	1.25	1.50	1.50	1.75	1.75	2.00	2.25	2.50	2.50	2.50	2.50	2.50	2.50	2.50	2.50	2.50	2.50	2.50	2.50	2.50	2.50	2.50	2.50	2.50	2.50	2.50	2.50	2.50	
	180	1.00	1.00	1.00	1.00	1.25	1.25	1.25	1.50	1.50	1.50	1.75	1.75	2.00	2.00	2.25	2.50	2.50	2.50	2.50	2.50	2.50	2.50	2.50	2.50	2.50	2.50	2.50	2.50	2.50	2.50	2.50	2.50	2.50	2.50	
	175	1.00	1.00	1.00	1.00	1.25	1.25	1.25	1.50	1.50	1.50	1.75	1.75	2.00	2.25	2.50	2.50	2.50	2.50	2.50	2.50	2.50	2.50	2.50	2.50	2.50	2.50	2.50	2.50	2.50	2.50	2.50	2.50	2.50	2.50	
	170	1.00	1.00	1.00	1.00	1.00	1.25	1.25	1.25	1.50	1.50	1.50	1.75	1.75	2.00	2.25	2.50	2.50	2.50	2.50	2.50	2.50	2.50	2.50	2.50	2.50	2.50	2.50	2.50	2.50	2.50	2.50	2.50	2.50	2.50	2.50
	165	0.75	1.00	1.00	1.00	1.00	1.00	1.00	1.25	1.25	1.50	1.50	1.50	1.75	2.00	2.25	2.50	2.50	2.50	2.50	2.50	2.50	2.50	2.50	2.50	2.50	2.50	2.50	2.50	2.50	2.50	2.50	2.50	2.50	2.50	2.50
	160	0.75	0.75	0.75	1.00	1.00	1.00	1.00	1.25	1.25	1.25	1.50	1.50	1.75	1.75	2.00	2.25	2.50	2.50	2.50	2.50	2.50	2.50	2.50	2.50	2.50	2.50	2.50	2.50	2.50	2.50	2.50	2.50	2.50	2.50	2.50
	155	0.75	0.75	0.75	0.75	1.00	1.00	1.00	1.00	1.25	1.25	1.25	1.50	1.50	1.75	2.00	2.25	2.50	2.50	2.50	2.50	2.50	2.50	2.50	2.50	2.50	2.50	2.50	2.50	2.50	2.50	2.50	2.50	2.50	2.50	2.50
	150	0.75	0.75	0.75	0.75	0.75	1.00	1.00	1.00	1.00	1.25	1.25	1.50	1.50	1.75	1.75	2.00	2.50	2.50	2.50	2.50	2.50	2.50	2.50	2.50	2.50	2.50	2.50	2.50	2.50	2.50	2.50	2.50	2.50	2.50	2.50
	145	0.75	0.75	0.75	0.75	0.75	0.75	0.75	0.75	1.00	1.00	1.00	1.25	1.25	1.50	1.50	1.75	2.00	2.25	2.50	2.50	2.50	2.50	2.50	2.50	2.50	2.50	2.50	2.50	2.50	2.50	2.50	2.50	2.50	2.50	2.50
	140	0.75	0.75	0.75	0.75	0.75	0.75	0.75	0.75	0.75	1.00	1.00	1.00	1.25	1.25	1.50	1.50	1.75	2.00	2.50	2.50	2.50	2.50	2.50	2.50	2.50	2.50	2.50	2.50	2.50	2.50	2.50	2.50	2.50	2.50	2.50



Outdoor Sensor - The outdoor sensor (p/n: 83604) is included in the burner kit, it must be connected to the Fuel Smart HydroStat Control 3250 prior to setting up the control.

10.0 INSTALLATION CHECKLIST

Start-up

1. Close automatic air vent and boiler drain cock.
2. Boiler water pH range should be 7.0 - 8.5. If conditions are above 7, contact local water treatment company.
3. Fill boiler with water until gauge reads 12-15 psi using auto fill device. Check for leaks.
4. Open automatic air vent 1 turn.
5. Bleed air from system. Starting at the lowest point in the building, open air vents one at a time and leave them open until water comes out. Close all air vents, except the automatic air vent(s).
6. Refill to correct pressure, 12-15 psi.

NOTICE

Purging the System - Ensure all air is purged from the heating system as it can result in uneven heat distribution, water circulation problems, and shorten the life of the boiler.

NOTICE

Antifreeze - If using antifreeze, use an inhibited propylene glycol specifically designed for hydronic systems.

ATTENTION

Avoiding Corrosion - Two things that contribute to boiler corrosion are air in the system, and boiler water with pH levels outside the recommended range. Be sure to check the pH level of the water before filling the boiler and bleed the system of air before firing the burner.

IMPORTANT

Pump Shaft Seals - Do not activate the burner until proper oil line connections have been made or failure of the pump shaft seal may occur.

Check-out

1. Boiler heating system is filled with water and pressurized to 12-15 psi.
2. Bring the boiler up to temperature, once at temperature purge air from the boiler.
3. Purge air from the heating system piping.
4. Check that heating system piping and boiler are free from leaks.
5. Ensure Oil Supply tank is properly installed and vented as per applicable standards.
6. Oil line is secured to the burner in accordance with the burner manufacturers instructions.
7. Oil line is purged and free from leaks.
8. Do not start burner unless smoke hood, clean out door, HydroStat 3250, breeching, and burner door are secured.
9. Burner has power and burner switch is turned on.
10. Verify sufficient combustion air is provided and applicable dampers are interlocked with burner.
11. Set burner flame by eye during initial start up. Make final adjustments with combustion test equipment.
12. Use the recommended air settings in Tables 2-1 to 2-3 as a starting point for the burner set-up.
13. Test HydroStat 3250 operation via the following methods: a) Adjust HI TEMP setting down until below boiler water temperature, burner should go out, circulator should continue pumping; b) adjust HI TEMP setting up until above boiler water temperature, burner should ignite.
14. Test field installed controls (i.e. external low water cut off or high limit) as per the control manufacturer's instructions included with the device. Burner should be operating when testing is conducted to verify that the burner changes state (on, off, on) when the controls are tested.
15. HydroStat 3250 settings are to the recommended settings defined in this manual.
16. Verify the boiler cycles with thermostat(s) demand (high temperature / low temperature).
17. Set thermostat to desired room temperature.
18. Allow boiler to complete at least one heating cycle to verify correct operation (minimum 15 minutes).
19. Review owner's responsibilities (Section 1.0) and annual maintenance (Section 11.0) with owner.
20. Leave this manual with the owner and affix the instructions close to the boiler.

Adjusting Combustion Air

NOTICE

Smoke Pump - A reliable, certified smoke pump is required to correctly set up this equipment.

CAUTION

Combustion Analyzer - To calibrate burner operation, use a calibrated combustion analyzer capable of measuring CO₂ and O₂ from oil burning boilers.

CAUTION

Smoke Test - All tests must be done with the burner covers or air intakes in place to simulate normal operation.

IMPORTANT

Avoid Condensation - Due to the high combustion efficiencies and low stack gas temperatures, great care must be taken to ensure the chimney isn't subjected to gas condensation. The gas temperature where the flue pipe enters the chimney must be a minimum of 240°F.

Air Settings:

1. Install applicable "burner package" as per burner installation instructions in Section 4.0.
2. Use the recommended air settings in Table 2-1 to 2-4 as a guideline.
3. Final adjustments should be made using test equipment and by verifying the CO₂ is between 11-13%.
4. To accurately set the combustion system, first establish a stable firing condition with a #1 smoke.
5. Increase the air setting slightly until a #0 smoke is obtained.
6. Establish a minimum of three 5 minute burner cycles.
7. With boiler operating, measure the CO₂ and O₂. Adjust pump pressure as necessary until the CO₂ is within the acceptable range of 11-13%.
8. Repeat the smoke test - #0 smoke should be detected.

Instructions to Installing Contractor

1. Ensure that the customer receives the Warranty Documentation included with the installation manual.
2. Leave the manual with the customer so they know when to call for annual maintenance and inspection.

WARNING

This boiler must have water in it whenever the burner is firing. Failure to comply may damage the unit, void the warranty, and cause serious injury or death.

11.0 ANNUAL MAINTENANCE AND INSPECTION

The building owner is responsible for scheduling boiler routine maintenance as described in this section. The boiler unit must be inspected at the beginning of every heating season by a Qualified Technician.

Annual Inspection Checklist

1. Make sure boiler is filled with water and fill valve is operating properly.
2. Inspect the condition of the combustion chamber.
3. Clean flue passages and combustion chamber at the end of each heating season.
4. Replace the oil filter.
5. Inspect the condition of the chimney and make recommendations for cleaning, if necessary.
6. Check heating system and boiler piping for leaks, make repairs as necessary.
7. Verify proper combustion air supply.
8. Verify proper draft.
9. Verify proper burner operation and combustion settings, including CO₂ and “smoke” tests. Records of annual testing and cleaning are required for any warranty consideration.
10. Verify proper control settings.
11. Verify proper operation of external controls on the boiler (i.e. low water cut off, high limit).
12. Verify proper operation of the hydronic system circulator, pressure relief valve, pressure regulating “fill valve”, expansion tank, air vents, etc.
13. Verify proper operation of the HydroStat 3250.
14. Test Low Water Cut-Off. Press and hold the Test/Settings button for 5 seconds. The display will read LCO. See instructions included with HydroStat for more details.
15. Clean Electro-Well every five years. To clean, remove scale or sediment deposits from areas in contact with boiler water. Reinstall well using pipe sealing compound. DO NOT use Teflon tape.
16. Refer to the manufacturer’s instructions included with the Fuel Smart HydroStat 3250 for more information on maintenance and operational procedures.

Close down for extended shutdown period

1. Turn off the thermostat(s) or set as low as it will go.
2. Close the oil supply valve (tank shutoff valve).
3. Turn the emergency power isolation switch off.
4. Clean the boiler to avoid premature aging.

Start-up after extended shutdown period

1. Check the boiler area for proper clearances to combustibles.
2. Inspect the boiler before preparing for start up.
3. Ensure there is oil in the oil tank.
4. Open the oil supply valve and ensure are no leaks.
5. Turn the thermostat(s) up.
6. Turn the emergency power isolation switch on.

NOTICE

If the burner has shut down on safety locate the red reset button on the burner and depress it, the burner should restart. If it fails to restart, or if it shuts down a second time, contact your service technician.

Annual Cleaning Instructions

Annually, before the heating season begins (fall) or immediately after it ends (spring), the Odyssey is to be cleaned and serviced by a licensed burner technician. If the burner is not used for an extended period of time, it must also be cleaned before being put back into service (start-up).

IMPORTANT

Handling Instructions - Accidental contact with potentially carcinogenic insulating materials can occur when cleaning the boiler. Read and follow the handling instructions in Section 11.0 regarding recommended personal protective equipment before commencing service on the boiler.

Cleaning the Flue Passages:

1. Remove power from boiler before servicing.
2. Close oil supply valves.
3. Remove the front cover and the burner door (see Figure 12-1 for boiler parts breakout).
4. Remove baffles.
5. Carefully clean flue passages with a fire tube brush.
6. Vacuum debris out of the burner and combustion chamber.
7. Reinstall the baffles and secure the burner door.
8. Open valves and restore power once reassembled.
9. Verify proper operation once the cleaning is completed.

Handling Instructions

Fiberglass and Ceramic Fiber Materials - Odyssey boilers use insulating materials to reduce heat exchanger losses and clearances to combustibles. It is important for installers and service personnel to know what these materials are, where they are located on the boiler, and how they should be handled. Refer to Table 11-1 for recommended handling instructions and Figure 12-1 for location of insulating materials.



Personal Protective Equipment Recommended - Read the following warnings and handling instructions carefully before commencing any service work.



Fiberglass (Potential Carcinogen) - Inhalation of airborne fibers from fiberglass materials have been listed as a possible cause of cancer in California.



Ceramic Fiber (Potential Carcinogen) - Use of Ceramic Fibers in high temperature applications (above 1000°C) can result in the formation of Crystalline Silica (cristobalite), a respirable silica dust. Repeated airborne exposure to crystalline silica dust may result in chronic lung infections, acute respiratory illness, or death. Crystalline silica is listed as a (potential) occupational carcinogen by the following regulatory organizations: International Agency for Research on Cancer (IARC), Canadian Centre for Occupational Health and Safety (CCOHS), Occupational Safety and Health Administration (OSHA), and National Institute for Occupational Safety and Health (NIOSH). Failure to comply with handling instructions in Table 11-1 may result in serious injury, long term health problems, or death.

Table 11-1 Handling Instructions for Fiberglass and Ceramic Fiber Materials

Reduce the Risk of Exposure	Precautions and Recommended Personal Protective Equipment
Avoid contact with skin and eyes	<ul style="list-style-type: none"> • Wear long-sleeved loose fitting clothing, gloves, and safety glasses (or goggles).
Avoid breathing in silica dust	<ul style="list-style-type: none"> • Wear a respirator with a N95-rated filter efficiency or better.¹ • Do not dry sweep silica dust. Pre-wet or use a vacuum with a high efficiency filter.
Avoid transferring contamination	<ul style="list-style-type: none"> • When installing or removing place the material in a sealable plastic bag. • Remove contaminated clothing after use. Store in sealable container until cleaned. • Wash contaminated clothing separately from other laundry.
First Aid Measures	<p>If irritation persists after implementing first aid measures consult a physician.</p> <ul style="list-style-type: none"> • Skin - Wash with luke-warm soap and water. • Eyes - Do not rub eyes; flush with water immediately. • Inhalation – Breathe in fresh air; drink water, sneeze or cough to clear irritated passage ways.
<p>Notes: ¹ Respirator recommendations based on CCOHS and OSHA requirements at the time this document was written. Consult your local regulatory authority regarding current requirements for respirators, personal protective equipment, handling, and disposal of RCFs.</p>	

* For more information on Fiberglass and Ceramic Fiber Materials contact CCOHS or OSHA.

Canada (CCOHS): Telephone directory listing under Government Blue Pages Canada—Health and Safety—Canadian Centre for Occupational Health and Safety; or website <http://www.ccohs.ca>.

United States (OSHA): Telephone directory listing under United States Government—Department of Labor—Occupational Safety and Health Administration; or website <http://www.osha.gov>.

12.0 PARTS LIST

For a list of parts that corresponds to the item numbers in the callouts, refer to Table 12-1. Note that some item numbers may appear more than once in the parts list depending on which model number is being referenced.

Building Owners - Replacement parts are available from your stocking wholesaler. Contact your local Installer or Wholesaler for assistance with parts.

Wholesalers - Contact NY Thermal Inc. directly when ordering replacement parts, 1-506-657-6000.

Installers - Contact NY Thermal Inc. directly if technical assistance required, 1-800-688-2575.

Figure 12-1 Boiler and Jacket

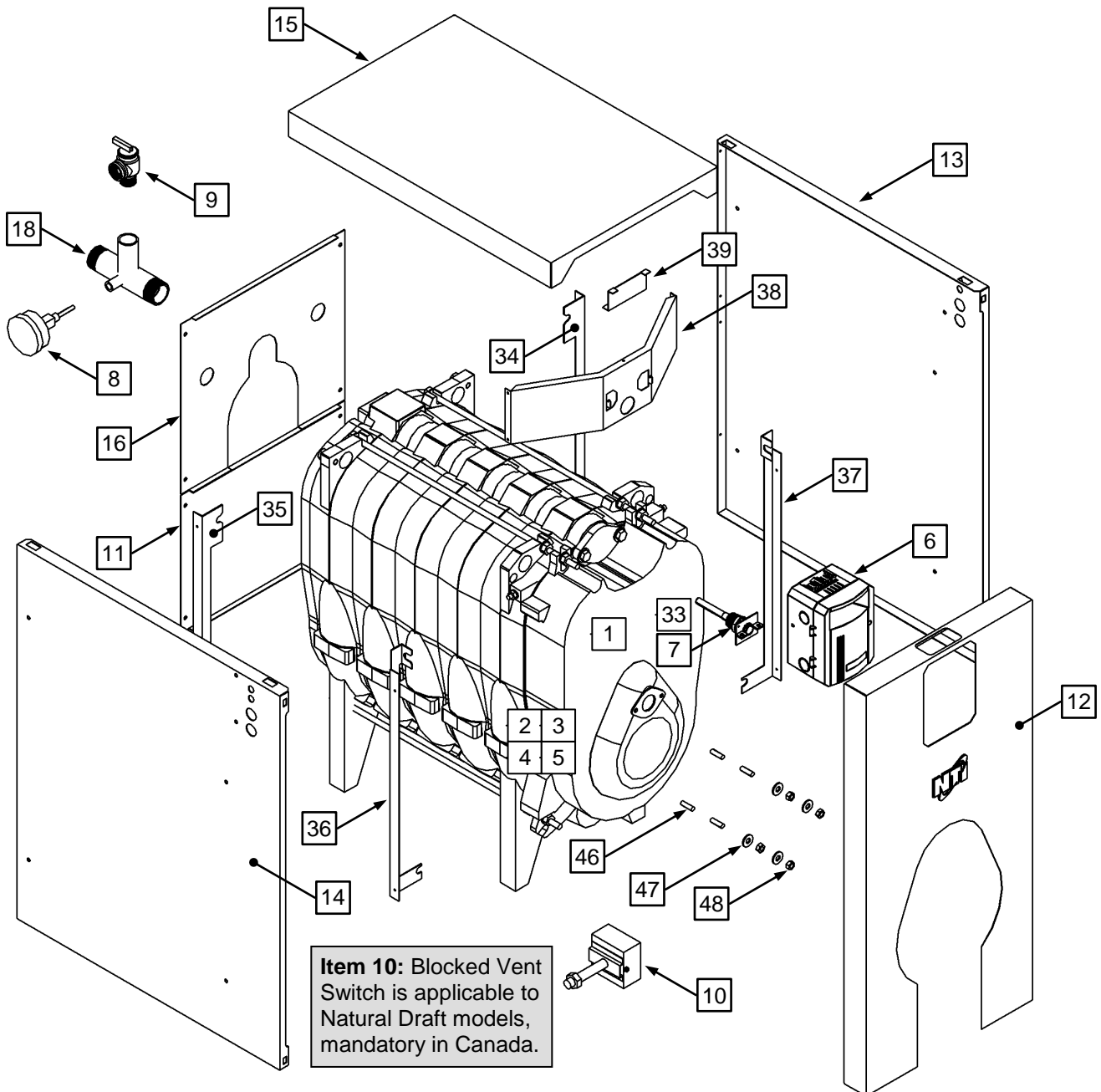

Figure 12-2 Burner Package

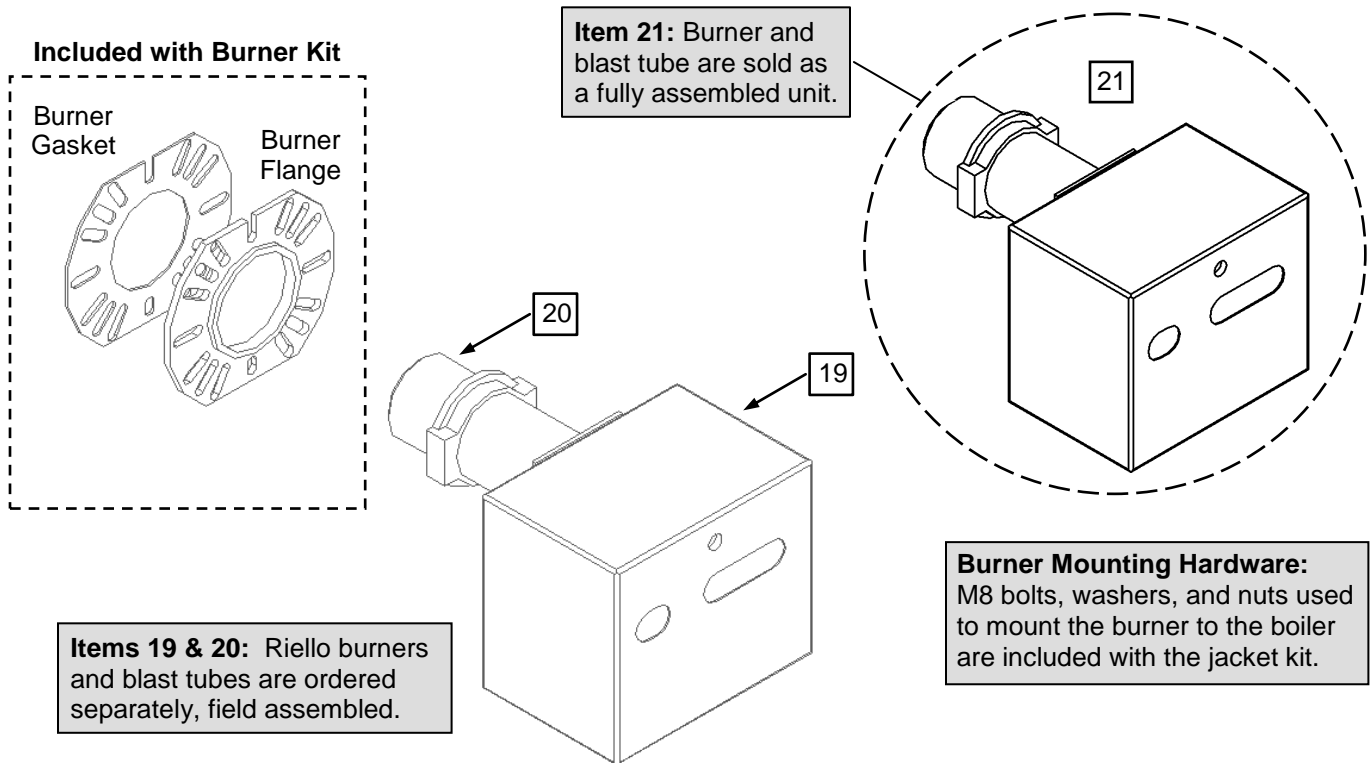

Figure 12-3 Direct Vent Components

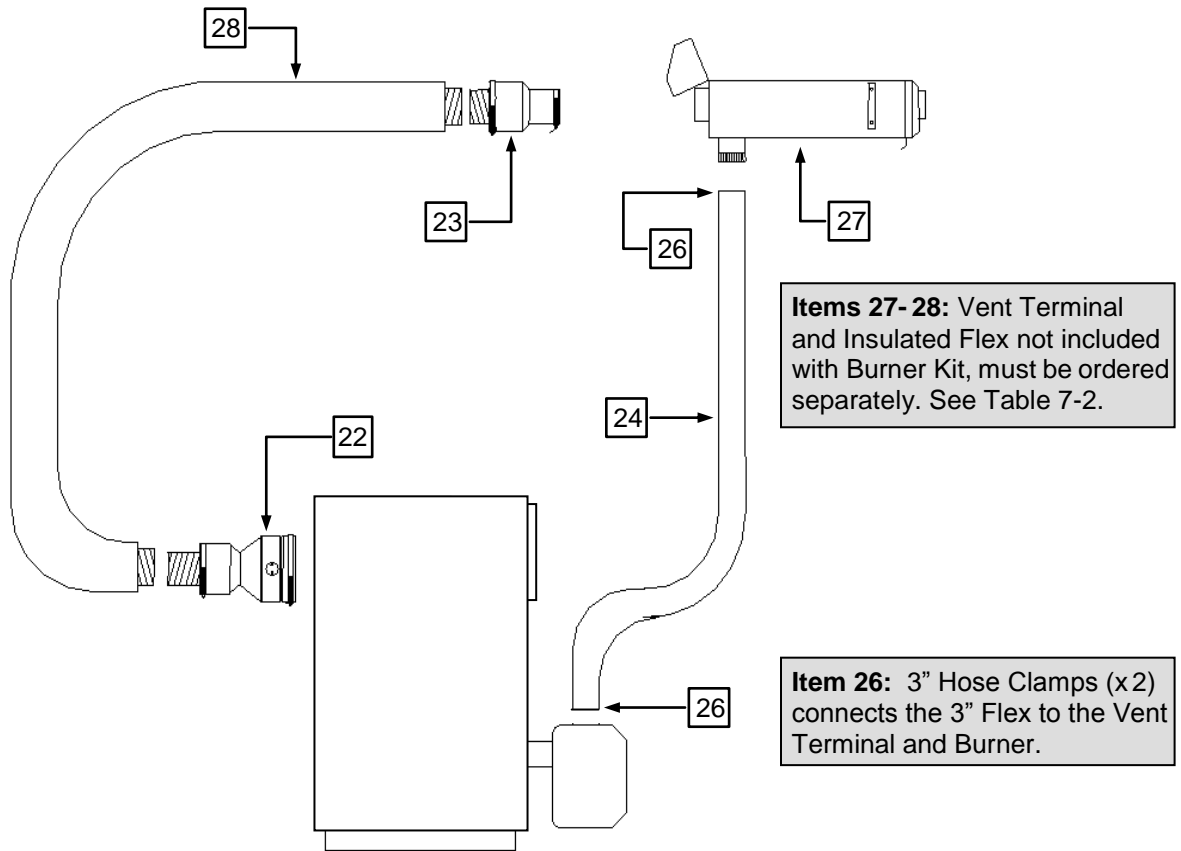

Table 12-1 Odyssey Parts List:

Item	Part #	Models	Description
1	CT80.	CT80-100	Boiler Only, CT80 (3 section)
1	CT120.	CT120-180	Boiler Only, CT120 (5 section)
1	CT215.	CT215-250	Boiler Only, CT215 (7 section)
2	82390	CT80-250	Sight Glass, Round, #R100385
3	82391	CT80-250	Sight Glass Gasket, #R100934
4	82727	CT80-250	Sight Glass Retainer
5	82728	CT80-250	Sight Glass Retaining Bolts
6	84787	CT80-250	Fuel Smart HydroStat Model 3250 (Sensor only p/n = 85052)
7	84788	CT80-250	Electro-Well™, Hydrolevel
8	81342	CT80-250	Tridicator
9	84877	CT80-250	Relief Valve, 30 psi
10	82905	CT80-250	Blocked Vent Switch (Natural Draft models only)
11	-	CT80-250	Jacket Common, Back-Bottom, HydroStat
12	-	CT80-250	Jacket Common, Front Cover, HydroStat
13	-	CT80-100	Jacket 82002, Right Side, HydroStat
13	-	CT120-180	Jacket 82003, Right Side, HydroStat
13	-	CT215-250	Jacket 82004, Right Side, HydroStat
14	-	CT80-100	Jacket 82002, Left Side, HydroStat
14	-	CT120-180	Jacket 82003, Left Side, HydroStat
14	-	CT215-250	Jacket 82004, Left side, HydroStat
15	-	CT80-100	Jacket 82002, Top Cover, HydroStat
15	-	CT120-180	Jacket 82003, Top Cover, HydroStat
15	-	CT215-250	Jacket 82004, Top Cover, HydroStat
16	-	CT80-250	Jacket Common, Back-Top, HydroStat
17	82894	CT80-250	Middle Baffle, 3 rd Pass, MPS 9, R102833, 1 piece (1/unit)
17	82895	CT80-250	Top-side Baffle, 2 nd Pass, MPS 10, R103040, 1 piece (2/unit)
17	82896	CT80-250	Bottom-side Baffle, 2 nd Pass, MPS 11, R103040, 2 pieces (2/unit)
18	84829	CT80-250	Outlet Tee, HydraStat
19	F3.CT	CT80-100	Burner, Riello F3, Natural Draft
19	F10.CT	CT215-250	Burner, Riello F10, Natural Draft
20	84024	CT80-100	Blast Tube, Riello F3 Natural Draft
21	F5.CT	CT120-180	Burner & Blast Tube, Riello F5, Natural Draft
21	81032	CT80-100	Burner & Blast Tube, Beckett, NYC601CT, Natural Draft
21	81032	CT120-250	Burner & Blast Tube, Beckett, NYC602CT, Natural Draft
21	BF5.CT	CT90-120	Burner & Blast Tube, Riello BF5, Direct Vent
22	81764	CT90-120	5"- 3" Ported Adapter
23	81098	CT90-120	3" Insulated Flex to Pipe Adapter
24	81138	CT90-120	3" Flex, 10'
25	83026	CT90-120	5"x 3" 90 Degree Elbow Ported Adapter (optional)
26	81625	CT90-120	Hose Clamps, 3"
27	81522-1	CT90-120	Direct Vent Terminal, 8" Wall
28	81109	CT90-120	Insulated Flex, 5'
28	81097	CT90-120	Insulated Flex, 10'
28	81110	CT90-120	Insulated Flex, 15'
28	81111	CT90-120	Insulated Flex, 20'
29	81522-2	CT90-120	Extended Direct Vent Terminal, 20" Wall (optional)
30	81453	CT90-120	Silicone, High Temperature, Nu Flex 302, Red (83ml)
31	81847	CT90-120	3" Direct Vent 90 Degree Elbow (optional)
32	81633	CT80-250	3" x 20' Flex Aluminum (optional)
33	84797	CT80-250	Grommet, Electro-well
34	84828	CT80-250	Odyssey, Ground Wire, HydraStat
35	-	CT80-250	Brackets, Rear - Left

Item	Part #	Models	Description
36	-	CT80-250	Brackets, Rear - Right
37	-	CT80-250	Brackets, Front - Left
38	-	CT80-250	Brackets, Front - Right
39	-	CT80-250	Control Panel, HydraStat
40	-	CT80-250	Hold Down Bracket, HydraStat
41	82893	CT80-250	Boiler Heat Exchanger Insulation, Fiberglass (White)
42	82892	CT80-250	Door Insulation
43	82726	CT80-250	Boiler Drain
44	82982	CT80-250	Bushing, Boiler Drain
45	82897	CT80-250	Ring Gasket, Boiler Drain
46	82490	CT80-250	Stud, M8 x 30mm (included with jacket kit)
47	76023	CT80-250	Washer, 5/16" Flat, Zinc Plated (included with jacket kit)
48	82350	CT80-250	Nut, brass, M8 (included with jacket kit)
49	82133	CT80-250	Ball Stud Retaining Clips, #R102017 (10 pcs/bag)
50	82975	CT80-250	Insulation Singe Unfaced, Duct Wrap DM225
51	81671	CT80-250	Plastic Bailer Twine

13.0 WARRANTY

NOTICE

A licensed and trained Heating Technician must install this appliance, otherwise the Warranty is VOID.

IMPORTANT

FREE extended coverage option only IF you register your boiler and installation with NY Thermal Inc. within 6 months of installation.

What Is Covered

We, the manufacturer, warrant that any parts or components of each new Boiler or Water Heater, will be supplied free of defects in material or workmanship. This warranty replaces any other warranty implied or expressed. All the durations, terms and conditions mentioned hereafter are for manufacturer defects due to material or workmanship only, and do not include misuse or normal wear of the equipment. Equipment returned for warranty consideration, will be evaluated upon the condition of the part when examined by NY Thermal Inc. or an authorized service representative. Improper handling and/or installation practices may VOID the warranty. See silver rating plate label on unit exterior for appliance type, model number, and serial number information.

To qualify for ANY warranty coverage, the installation **must comply** with the installation and operating instructions provided with the appliance, and **must comply** with the “Terms and Conditions” of this warranty. Labor is not covered by this warranty. All warranty coverage is offered to the original owner and location only, and is not transferable

BASIC COVERAGE:

We will repair or replace any defective component supplied or manufactured by NTI for a period of one year (5 years for the pressure vessel), beginning from the date of installation without, however, covering the installation itself.

NOTICE

Basic Coverage warranty period will commence from the date of manufacture, if the installation is **NOT** registered at www.ntiboilers.com/products/product-registration.html within 6 months of installation.

EXTENDED COVERAGE:

We will repair or replace a defective pressure vessel for a period of eleven (11) years, at 100% coverage, beginning from the date of installation without, however, covering the installation itself. After the 11th year, the pressure vessel warranty coverage is prorated from 90% coverage in year 12, to 10% coverage in year 20.

NOTICE

To qualify for Extended Coverage, the installation must be registered at www.ntiboilers.com/products/product-registration.html within 6 months of installation. By registering your installation, you authorize NTI to contact you directly in the event of any product advisories associated with your NTI boiler or water heater.

COVERAGE SUMMARY:

Coverage	Coverage Period	Coverage Rate	Components Covered	Additional Terms and Conditions
BASIC	Year 1	100%	All parts (including Pressure Vessel)	Coverage Period commences on the date of installation when the boiler installation is registered at www.ntiboilers.com/products/product-registration.html within six months of installation, otherwise the Coverage Period commences from the date of manufacture.
	Years 2 through 5	100%	Pressure Vessel only	
EXTENDED	Years 6 through 11	100%	Pressure Vessel only	Not applicable to Tankless Coil. Installation must be registered at www.ntiboilers.com/products/product-registration.html within six months of installation to qualify for Extended Coverage.
	Years 12 through 20	100-10%		

Terms and Conditions

1. This warranty is VOID if:
 - a. The appliance is not installed and serviced by a licensed and trained Heating Technician.
 - b. The installation is not in accordance with this manufacturer’s manuals, local codes, and regulations.
 - c. The heating system does not provide and ensure required flow through the heat exchanger when the burner is on.
 - d. Deformation occurs due to freezing; improper storage or handling; improper firing or firing without water.
2. Any repairs or replacements made without authorization by or notification to the manufacturer.
3. This warranty does not cover the labour and shipping costs associated with installing a repaired or replaced boiler.
4. Installations determined to have any leaks in the entire heating system causing make up water to enter the system (e.g. Solder leaks, coil gasket leaks, frequent system drainage).
5. Decision of warranty repairs or replacements to appliances will be at the discretion of the manufacturer or authorized service representative.
6. This warranty is to the original owner only.

What To Do In The Case of A Warranty Service Problem

1. Contact your installing contractor or service provider. Do not call NTI.
2. If your contractor or service representative requires further help, they will contact us directly.
3. If you cannot contact your contractor or service representative, contact us at 1-506-657-6000 to the attention of the Service Department.
NOTE: NTI cannot provide technical assistance to homeowners unless they are a licensed and trained Heating Technician.
4. We as the appliance manufacturer will replace or credit the parts under warranty; credits are issued to the authorized wholesaler at their cost, so do not purchase replacement parts from suppliers with hopes of receiving 100% credit; it is recommended to receive all your warranty parts from your authorized service representative or us directly, at no charge (if under the warranty coverage).
5. We care about the quality of service you receive, so please let us know if you have complaints concerning your authorized service representative.

For Service Contact:

Name: _____

	Warranty Registration Form Odyssey Oil Boiler
Owner’s Name	
Address	
City	
Province / State	
Boiler Model	
Serial Number	
Installer’s Name	
Date of Installation	
Complete this form, photocopy, and return to: NY Thermal Inc. 30 Stonegate Dr. Saint John, N.B. E2H 0A4 Canada	



NTI Boilers Inc. 30 Stonegate Dr. Saint John, NB E2H 0A4 Canada
Technical Assistance: 1-800-688-2575
Website: www.ntiboilers.com
Fax: 1-506-432-1135