

Tft/TFTN – Common Vent Manifold System

Model Numbers: CVM2 300-399 & CVM3 300-399

Applicable to Boiler Models: Tft300, Tft340, Tft399, TFTN340, TFTN399

Version Date: 2024-06-24



INSTALLATION AND OPERATION INSTRUCTIONS FOR Tft/TFTN COMMON VENT MANIFOLD SYSTEM



TABLE OF CONTENTS

| | |
|--|----|
| 1.0 INTRODUCTION | 2 |
| 2.0 SPECIFICATIONS..... | 3 |
| 3.0 BOILER LOCATION..... | 7 |
| 4.0 ASSEMBLY INSTRUCTIONS..... | 10 |
| 5.0 TERMINATION OPTIONS - DIRECT VENT..... | 17 |
| 6.0 CHECKLIST..... | 23 |

HAZARD SYMBOLS AND DEFINITIONS



Danger Sign: Indicates a hazardous situation which, if not avoided, will result in serious injury or death.



Warning Sign: Indicates a hazardous situation which, if not avoided, could result in serious injury or death.



Caution Sign plus Safety Alert Symbol: Indicates a hazardous situation which, if not avoided, could result in minor or moderate injury.



Caution Sign without Safety Alert Symbol: Indicates a hazardous situation which, if not avoided, could result in property damage.

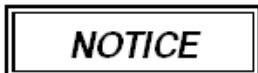

Notice Sign: Indicates a hazardous situation which, if not avoided, could result in property damage.



This Common Vent System must be installed by a licensed and trained Heating Technician, or the **Warranty is Void**. Failure to properly install this system may result in property damage, serious injury to occupants, or possibly death.

1.0 INTRODUCTION

This manual is to be used in addition to the Installation and Operation Manual provided with the respective boiler (P/N 99984535 for Tft300-399; P/N 99987137 for TFTN340-399).

General Installation Requirements

The installation of the Tft/TFTN – Common Vent Manifold System, piping and termination must conform to the requirements of this manual, the Installation and Operation Instructions for the Tft/TFTN Boiler, your local authority, and the National Fuel Gas Code ANSI Z223.1 and or CAN/CGA B149 Installation Codes. Where required by the Authority, the installation must conform to the standard for; “Controls and Safety Devices for Automatically Fired Boilers ANSI/ASME CSD-1.”

The Tft/TFTN – Common Vent Manifold System contains the components required to manifold the Exhaust Outlet and Combustion Air-intake of 2 or 3 Tft300-399 boilers, or 2 or 3 TFTN340-399 boilers.

NOTE: You cannot common vent Tft and TFTN boilers together.



Read and understand this entire document prior to proceeding with the Common Vent installation. Failure to follow the instructions outlined in this document will result in property damage, serious injury or death.

Applicable Boiler Models

The Tft/TFTN – Common Vent Manifold System is designed for use with NTI Tft/TFTN300-399 boilers only; and is only compatible with 6” Centrotherm – InnoFlue venting. Do not combine venting materials from different manufactures or use with boilers other than models Tft/TFTN300-399; see Table 2-1.



Boiler models Tft/TFTN300-399 cannot be installed in a common vent system with any other boiler model. Failure to follow this warning can cause incorrect boiler and venting system operation, and may result in property damage, serious injury or death.



Do not install the Tft/TFTN – Common Vent Manifold System with vent parts from other manufactures or brands; use only Centrotherm – InnoFlue. Failure to follow these instructions may result in property damage, serious injury or death.

User Responsibilities

The Common Vent Manifold System, common venting and termination must be installed and regularly inspected by a licensed technician. **NOTICE:** some applications may require more frequent service and inspection. As the User/Owner of this equipment, you are responsible for ensuring the maintenance is performed at the required intervals.



Failure to have the venting system regularly serviced and inspected by a licensed technician may result in property damage, serious injury or death.

Installer Responsibilities

As the licensed technician it is your responsibility to ensure the installation is performed in accordance with this manual, the Installation and Operation Instructions provided with the boilers, as well as any applicable local or National installation codes. It is also your responsibility to inform the User/Owner of their obligation with respect to the above description under “User Responsibilities.” Failure to follow this warning could result in fire, serious injury, or death.

2.0 SPECIFICATIONS

Common Vent Manifold Configurations

The Tft/TFTN – Common Vent Manifold System is available in 2 configurations; CVM2 300-399 (configured for 2 Tft/TFTN300-399 boilers) and CVM3 300-399 (configured for 3 Tft/TFTN300-399 boilers). The manifolds can be assembled to direct Exhaust and Combustion Air-intake piping to the left or to the right.

Table 2-1 Common Vent Manifold Systems

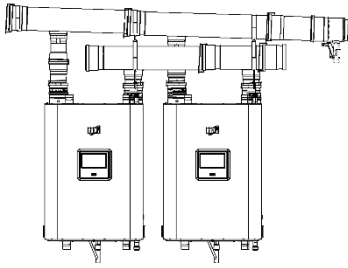
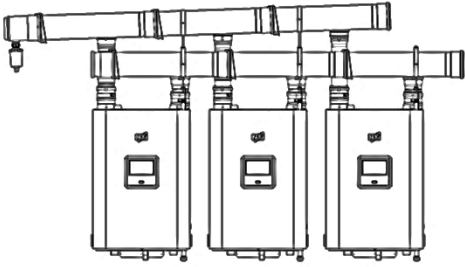
| PART NO. | DESCRIPTION | COMMON VENT MANIFOLD SYSTEM IMAGE |
|--------------|--|--|
| CVM2 300-399 | <p>Common Vent Manifold System for the Exhaust Vent Outlet and Combustion Air-intake of two (2) Tft/TFTN300-399 boilers.</p> <p>NOTE: When piping to the left, Exhaust Extension pipe must be used to clear the siphon.</p> | <p>(LEFT-SIDE Exhaust and Combustion Air-intake piping illustrated)</p>  |
| CVM3 300-399 | <p>Common Vent Manifold System for the Exhaust Vent Outlet and Combustion Air-intake of three (3) Tft/TFTN300-399 boilers.</p> | <p>(RIGHT-SIDE Exhaust and Combustion Air-intake piping illustrated)</p>  |

Inspection

Prior to the installation of the Common Vent Manifold System, conduct a visual inspection of each vent component to ensure the parts were not damaged during shipping and were shipped complete.



WARNING Do not install broken or damaged venting components; doing so may result in property damage, serious injury, or death.

Table 2-2 Parts Included with Common Vent Manifold System

| DESCRIPTION | | CVM2 | CVM3 | PART No. | IMAGE |
|---|-------------------------|------|----------------|------------|-------|
| Air-Inlet Appliance Adapter 4" (9" long) | | 2 | 3 | 6500788000 | |
| Exhaust Appliance Adapter 4" ² | 11" (short) | 1 | 1 | 6500788100 | |
| | 12" (medium) | 1 | 1 | 6500788200 | |
| | 13" (long) ¹ | 0 | 1 ¹ | 6500788300 | |
| Siphon | | 1 | 1 | 6000085070 | |
| Branch 6" x 4" ³ | | 4 | 6 | 6000085071 | |
| Cap 6" | | 1 | 1 | 6500788400 | |
| Exhaust Extension 6" x 12" ⁴ | | 1 | 1 | 6500788500 | |
| Connector Rings | 4" | 14 | 21 | 6500788600 | |
| | 6" | 4 | 6 | 6000085075 | |
| Elbow 4" | | 4 | 6 | 6000085076 | |
| Horizontal Drain 6" | | 1 | 1 | 6000085077 | |
| Non-Return Valve 4" | | 2 | 3 | 6000086378 | |
| Air-Inlet Support ⁵ | | 2 | 3 | 6000085081 | |
| Exhaust Support ⁶ | | 2 | 3 | 6000085082 | |
| Centrocerin | | 1 | 1 | 6500788700 | |

Notes:

¹ The "long" Exhaust Appliance Adapters are only supplied with CVM3 (3-boiler) common venting systems.

² Exhaust Appliance Adapters are supplied with specific lengths to attain the required 3/8" per foot slope.







³ Branch 6" x 4" are to be cut to size by the installer as show in Section 4.0 of this manual.

⁴ Exhaust Extension 6" x 12" – required only when exhausting from left. Refer to Figure 4.1 Piping to the LEFT.

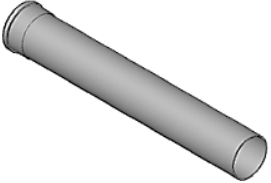
⁵ Air-Inlet Supports includes 2 – 1/4" x 1" Machined Screws and 2 – 1/4" x 3/4" Drill Point Screws.

⁶ Exhaust Supports includes 2 – 1/4" x 1" Machined Screws.

Table 2-3 Acceptable Common Vent and Termination Parts ¹

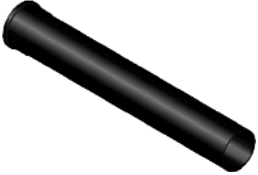
| DESCRIPTION | COMMENTS | IMAGE |
|---|---|---|
| Elbow 6" ² | - |  |
| Straight Pipe Length 6" ³ <ul style="list-style-type: none"> • 6" x 14.5" • 6" x 26.5" • 6" x 38.5" • 6" x 74.5" | - |  |
| Connector Ring 6" ⁴ | Mandatory at every connection of the Common Vent Manifold. |  |
| Support Clamps 6" ⁵ | Mandatory every 75" spaced on vertical runs and every 40" on horizontal runs. |  |
| Bird Screen PPs-UV 6" | PPs-UV Components are also available, for vent terminations where the color black is preferred. |  |
| End Pipe PPs-UV <ul style="list-style-type: none"> • 6" x 19.7" • 6" x 39.4" | |  |
| Elbow PPs-UV 6" | |  |
| Elbow PPs-UV 6" | |  |
| Straight Vent Length PPs-UV <ul style="list-style-type: none"> • 6" x 26.5" | |  |

Notes:

¹ With the exception of the Common Vent Manifold System, the installer is responsible for supplying all the required venting components; including pipe lengths, termination, Connector Rings, and Support Clamps.

² When determining the maximum vent lengths each 6" diameter Elbow (87° and 45°) are equivalent to 5 feet of pipe length.

³ The total maximum equivalent vent length for each Exhaust and Air-Inlet is 100 feet.

⁴ Connector Rings are required on every connection within the common vent manifold provided in this kit.

⁵ Support Clamps are required every 75" for vertical runs and every 40" for horizontal runs.

Consult Centrotherm – InnoFlue Eco Systems (1-518-434-3400 or info@centrotherm.us.com) instructions for further details.

Exhaust Vent & Combustion Air-Inlet Piping

The Tft and TFTN are certified as “Category IV” boilers requiring a “Special Venting System” designed for pressurized venting. The Exhaust and Combustion Air-intake must be **DIRECT VENTED** to the outdoors, using the venting materials outlined in Table 2-3 of this manual. Under no conditions shall the products of combustion be vented into a masonry chimney.

Centrotherm – InnoFlue is the only manufacture to be used for the Common Vent Manifold System, common venting and termination. The common vent and termination parts are to be field supplied by the Installer. Consult Centrotherm – InnoFlue Eco Systems (1-518-434-3400 or info@centrotherm.us.com) instructions for further details.

Pipe Length – The maximum equivalent vent length for the Exhaust and Combustion Air-intake is 100 feet each. The minimum length is 5 feet each.

Elbows – Both 45° and 87° Elbows are equivalent to 5 feet of pipe length.

NOTICE

Centrotherm – InnoFlue is ULC-S636 and UL-1738 approved for use in Canada and the United States. Centrotherm – InnoFlue 6” diameter polypropylene piping is the only product approved for use with the Tft/TFTN – Common Vent Manifold System.

Supporting Venting

Connector Rings – mandatory on every exhaust and air-intake connection that make up the common vent system.

Connector Rings lock the venting together and prevent it from pulling apart. Consult Centrotherm – InnoFlue Eco Systems (1-518-434-3400 or info@centrotherm.us.com) instructions for further details, and for requirements on installing the remainder of the venting system.

Support Clamps – shall be installed on the exhaust and air-intake piping every 75” for vertical runs and every 40” for horizontal runs. Support clamps alleviate strain on the vent connections, and prevent the piping from drooping. Consult Centrotherm – InnoFlue Eco Systems (1-518-434-3400 or info@centrotherm.us.com) instructions for further details.

DANGER

Exhaust and Combustion Air-intake venting requires Support Clamps spaced every 75” for vertical runs and every 40” for horizontal runs and Connector Rings on every connection. Failure to follow these instructions may result in property damage, serious injury or death.

Termination Options

Centrotherm – InnoFlue 6” diameter components are the only parts approved for terminating the venting of the common vent system, see Table 2-3. Consult Centrotherm – InnoFlue Eco Systems (1-518-434-3400 or info@centrotherm.us.com) instructions for further details.

Termination Configurations are decided by the installer and must conform to Section 5.0 of this manual and the boiler installation manual.

3.0 BOILER LOCATION

Boiler Mounting

There are two methods of mounting Tft/TFTN300-399 boilers. One option is to mount the boilers directly to the wall using the wall mounting brackets provided with the boilers. The other method is to use NTI's Floor Stands (P/N 84624) and Floor Stand Twinning Kit (P/N 85063).

CAUTION Mounting the boilers requires a minimum of two people to lift the boilers into place. Failure to follow these instructions may result in property damage or personal injury.

Wall Mounting Method

Before installing the Wall Mounting Brackets on the wall ensure there is sufficient wall space to work with, both vertically and horizontally.

Horizontal Space Requirements – the common vent manifold is designed for a specific horizontal spacing of the boilers (see Figure 3-1); when assembled, a two-boiler cascade will require a minimum of 70" of horizontal space, while a three-boiler cascade will require a minimum of 100".

Clearance Above Boiler – allowing a minimum of 36" above the wall mounting bracket (see Figure 3-1) will ensure that the assembled common vent manifold will adequately clear the ceiling, however, additional clearance could be needed to account for the upward slope of additional horizontal venting.

Clearance Below Boiler – installing the wall mount brackets 48" above the floor (see Figure 3-1) ensures the minimum installation clearance below the boiler, however, it is recommended to install the brackets at least 56" above the floor to improve serviceability of the boilers' condensate trap.

1. Secure the boiler Wall Mount Brackets to the wall using the brackets included with your Tft/TFTN boiler. Spacing between the brackets will depend on the bracket type; see Figure 3-1.

Figure 3-1 Wall Mount Bracket Spacing

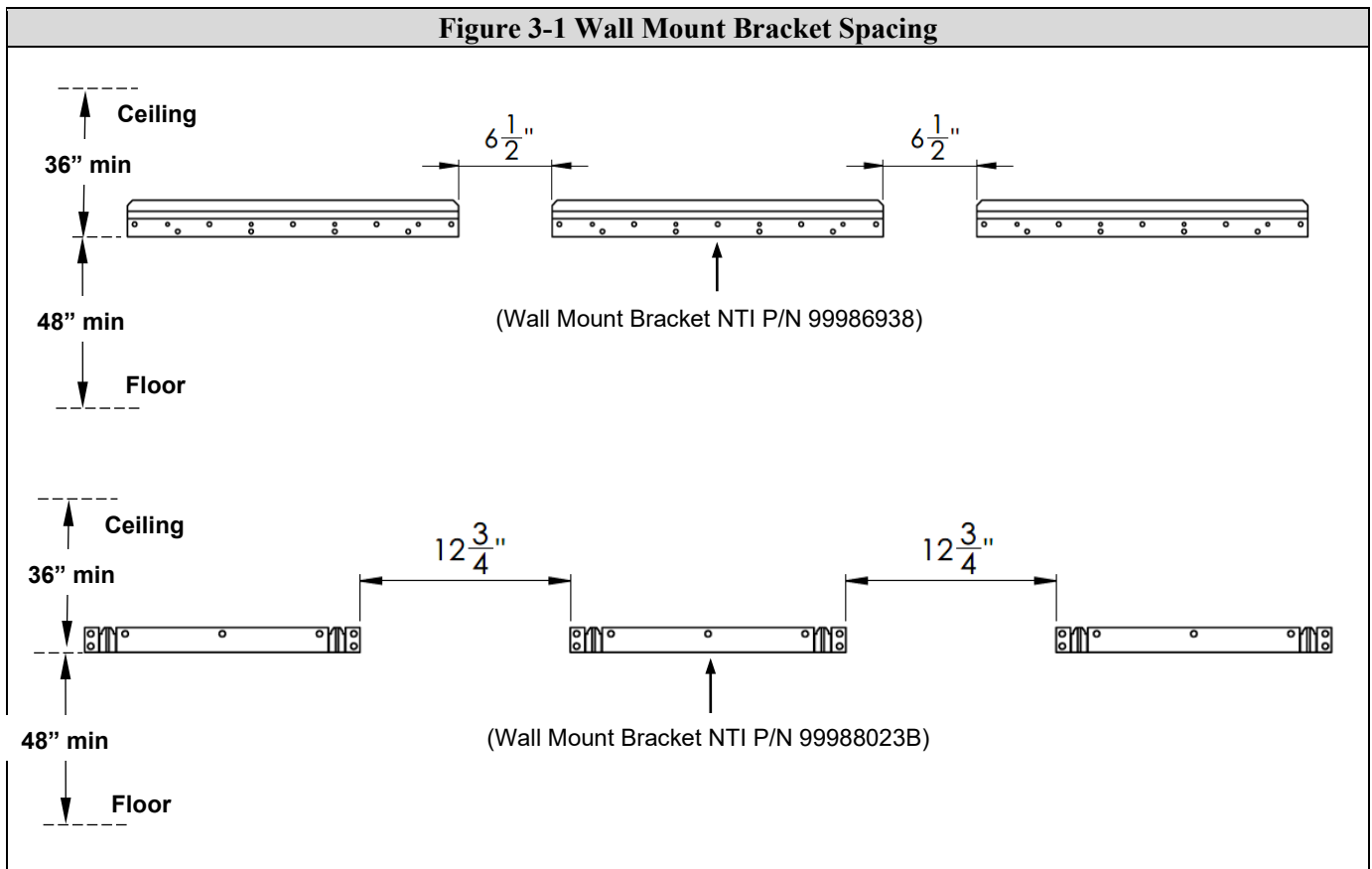

2. Install the boilers on the wall ensuring that they are plumb and level (refer to wall mounting instructions in the boiler installation and operation manual). Measure the distance between each boiler, they should be 4-1/4" apart (+/- 1/8"); see Figure 3-2.

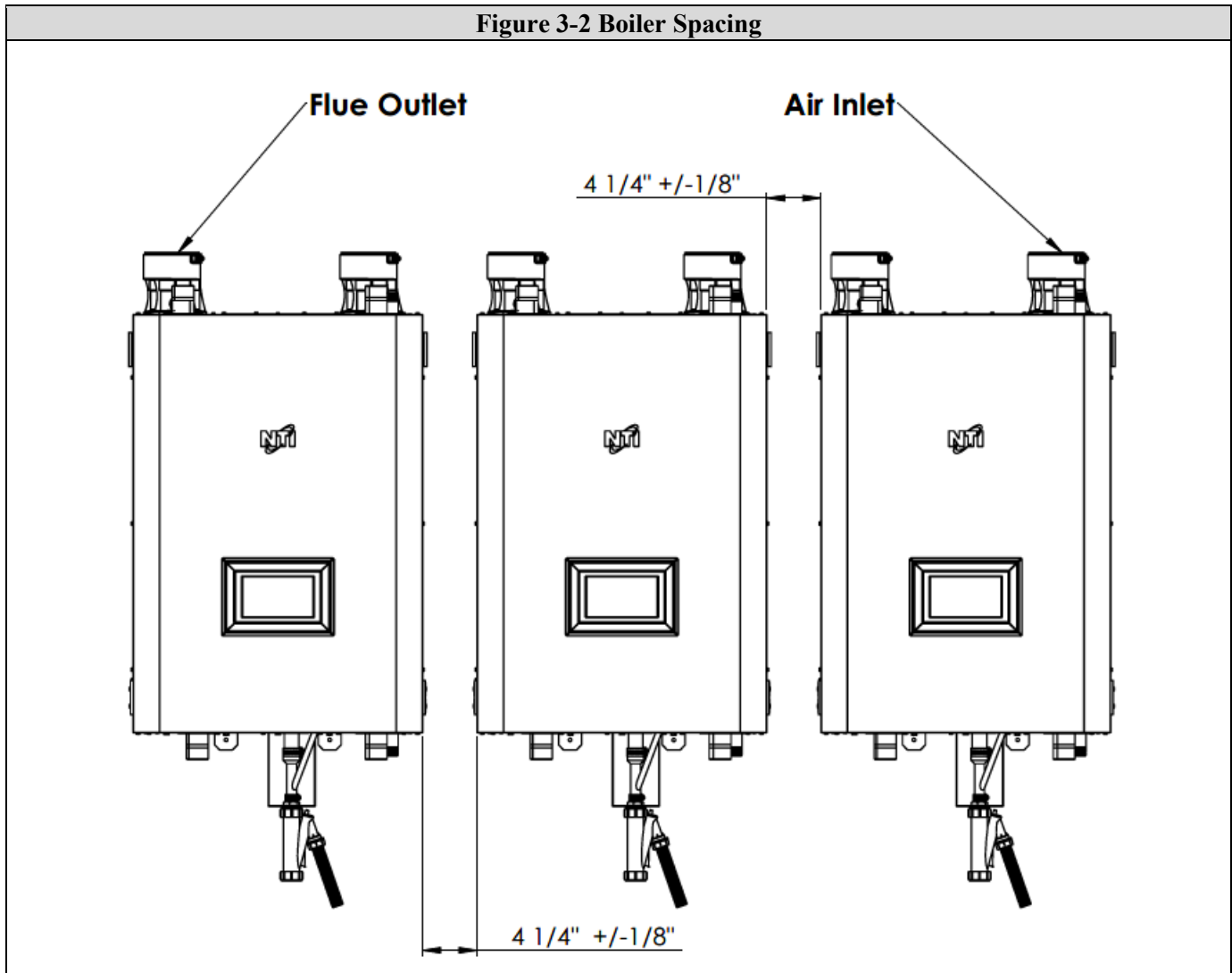

Floor Stand Mounting Method

NTI's Floor Stands and Twinning Kits are designed with precise height and spacing for assembling the Common Vent Manifold System. One Twinning Kit is required to joint two Floor Stands together; two Twinning Kits are required to join three Floor Stands together.

- P/N 99984624 – Tft/TFTN300-399 Floor Stand
- P/N 99985063 – Floor Stand Twinning Kit

1. Follow the directions outlined in the Floor Stand installation instructions to assemble the individual Floor Stands and connect using the Twinning Kit(s). Once assembled, ensure the bolts are fastened securely. Level the assembled stand vertically and horizontally using the adjustable leveling legs.

Figure 3-3 NTI's Floor Stands & Connector Kits

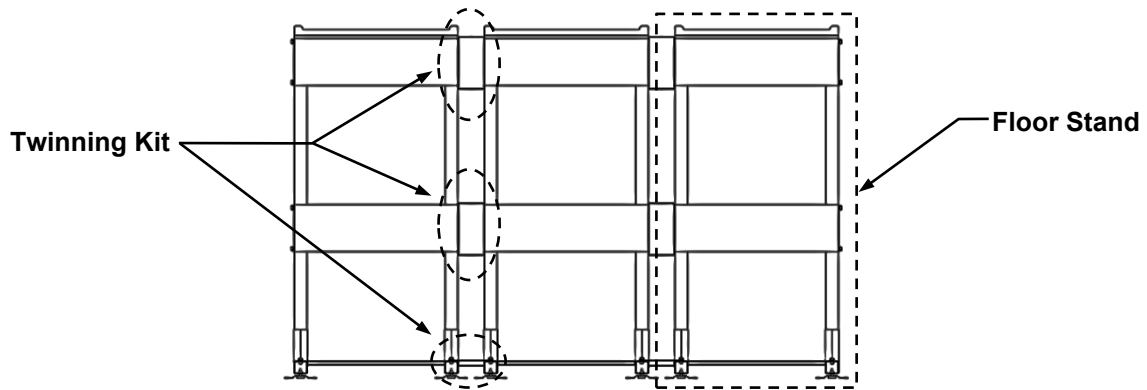

2. Secure the assembled Floor Stand to the floor using the provided Floor Anchor Brackets and field supplied anchors, see installation instructions provided with the Floor Stand.
3. Install the boilers on the Floor Stands see Figure 3-4.

Figure 3-4 Boilers Floor Stand Mounted

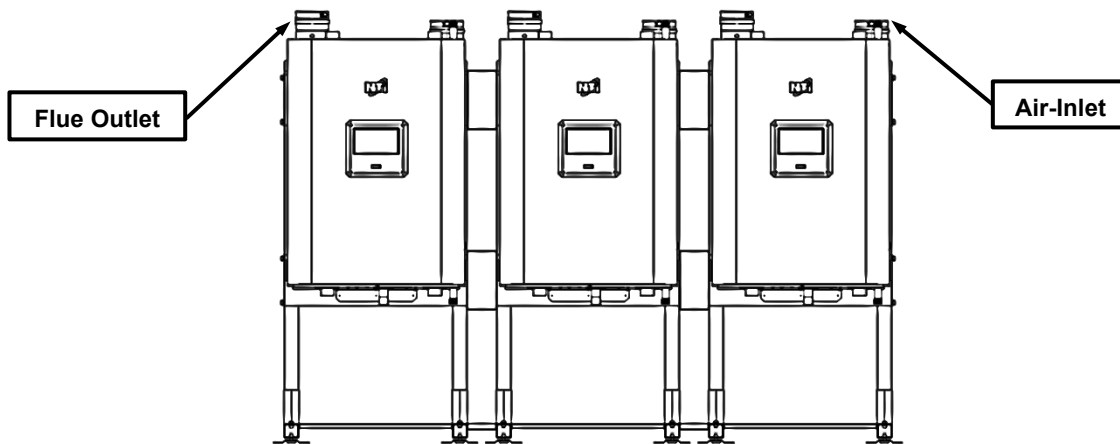

4. Secure bottom bracket to the boiler and center cross member of the stand, refer to the Floor Stand installation instructions.

4.0 ASSEMBLY INSTRUCTIONS

Before commencing the assembly of the Common Vent Manifold System, identify which direction to direct the Exhaust Gas and Combustion Air-Inlet piping. The direction will dictate the length the 6" x 4" branches need to be cut to.

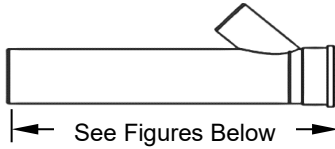
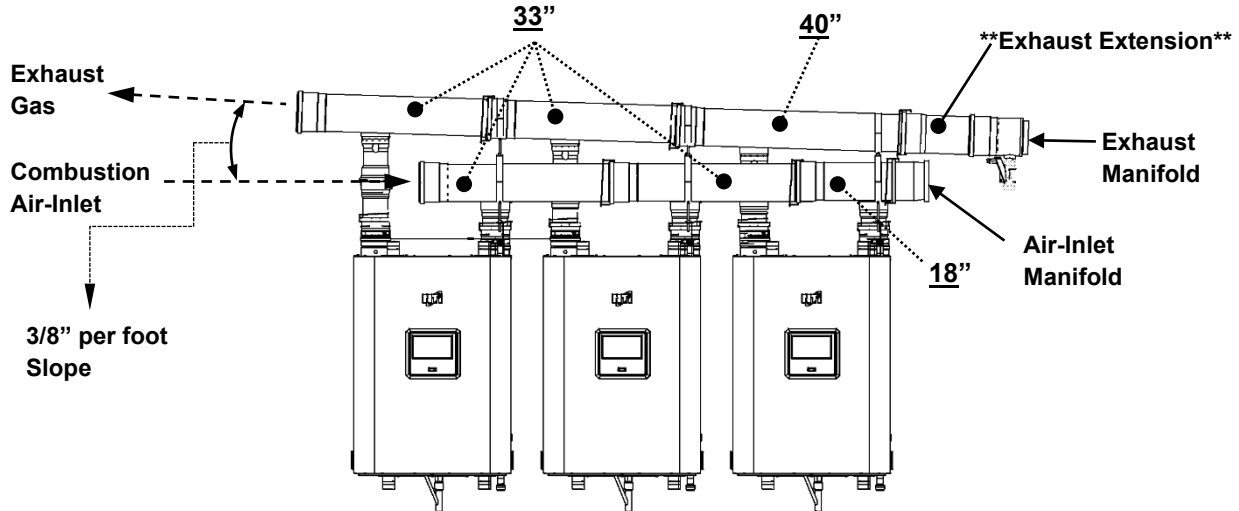

Figure 4-1 Piping to the LEFT



Branch 6" x 4" – when directing the exhaust gas and combustion air-inlet piping to the LEFT, the overall length of the branches must be reduced to the lengths indicated in Figure 4-1; 18" and 40" for the right-side Combustion Air-Inlet and Exhaust Gas outlet respectively, 33" for the others.

NOTE: This only applies to CVM2 300-399 and CVM3 300-399 being piped to the **LEFT**. Exhaust Extension is used only when piping to Left.

Figure 4-2 Piping to the RIGHT

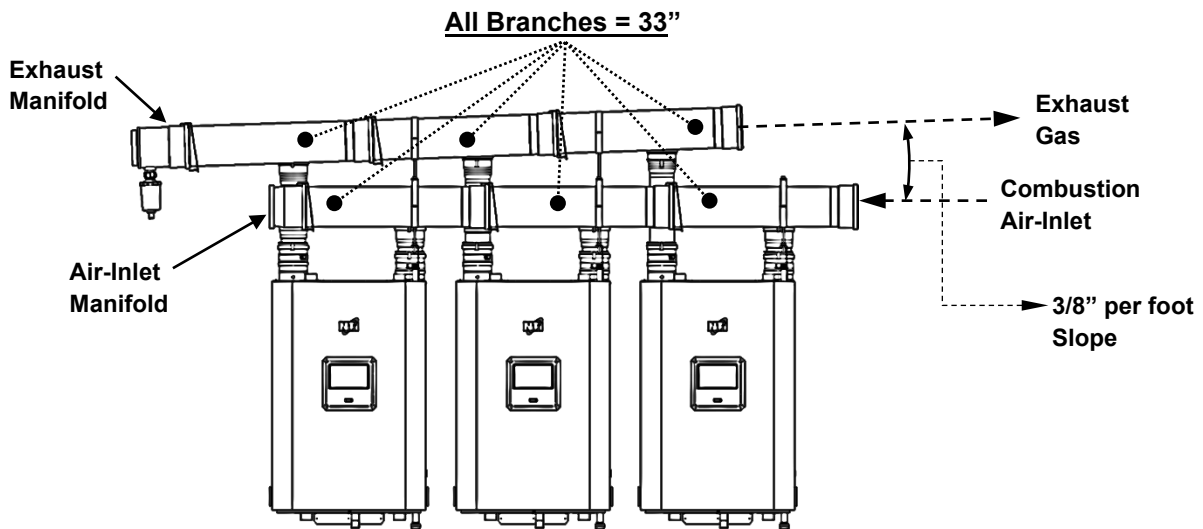

Branch 6" x 4" – when directing the Exhaust Gas and Combustion Air-Inlet piping to the RIGHT, the overall length of the branches must be reduced to the length indicated in Figure 4-2; 33" for each Branch.

NOTE: This only applies to CVM2 300-399 and CVM3 300-399 being piped to the **RIGHT**.

Lubricate During Assembly

When assembling the Exhaust and Air-Inlet piping, apply Centrocerin (a water-based lubricant) to each gasket and male end, to ease the assembly process, and to prevent gasket damage.

CAUTION Failure to apply Centrocerin lubricant to each connection may cause the gasket to be damaged or dislodged during assembly, resulting in property damage, personal injury or death.

NOTICE The Common Vent Manifold System and the first 5 feet of the common vent shall not be enclosed or covered and must be easily accessible for maintenance and inspection; failure to do so may lead to property damage.

Exhaust Vent Slope

The Exhaust Manifold must slope back towards the boilers a minimum of 3/8" per linear foot; the Exhaust Appliance Adapters and the Exhaust Supports have been pre-sized to achieve the required slope, see Step 8 of this section.

CAUTION Failure to assemble the Common Vent Manifold System in the correct order may result in property damage, personal injury or death.

Connector Rings

Connector Rings are mandatory on every connection within the Common Vent Manifold, with the exception of the Exhaust and Air-Inlet connection at the boilers, which are secured with a gear clamp. The Connector Rings are mandatory and prevent the pipe connections from coming apart. See Figure 4-4 for Connector Ring Installation Instructions.

Figure 4-3 Connector Ring Installation Instructions

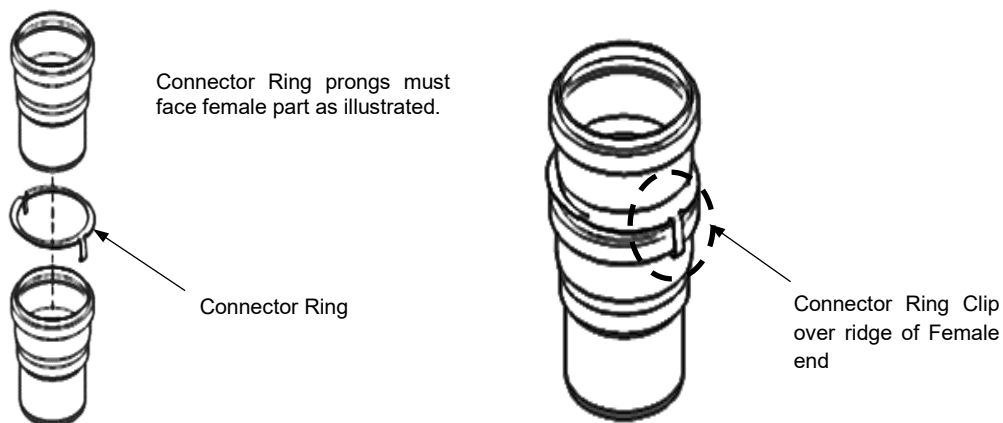

WARNING Failure to properly install Connector Rings on every connection may result in property damage, serious injury or death.

NOTICE Assemble the Common Vent Manifold System, including the Exhaust and Air-Inlet Supports, as shown in this section. The instructions and illustrations in this section demonstrate the exhaust gas and combustion air-inlet piped to the **RIGHT**.

Air-Inlet Manifold Assembly Instructions (Steps 1-6)

Apply Centrocerin lubricant to each gasket and male pipe end

Tft340-399

1. **Air-Inlet Supports (Tft340-399)** – Remove the front door of the boiler. Using two 1/4" x 3/4" Drill Point Screws, fasten the Air-Inlet Support to the front right corner of the boiler cabinet as illustrated. Repeat for each boiler.

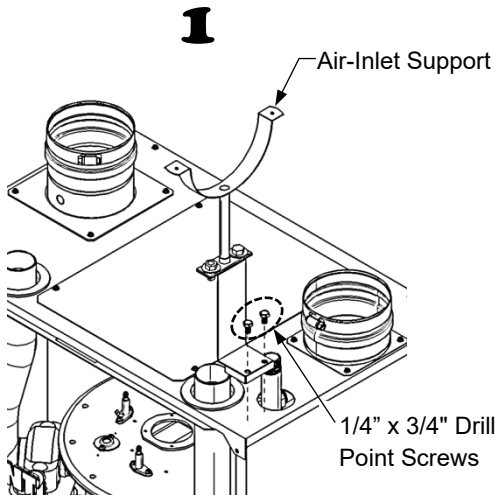

2. **Assembled Height (Tft340-399)** – Ensure the assembled height of the Air-Inlet Supports measure 10" from the top of the boiler as shown; adjust as necessary.

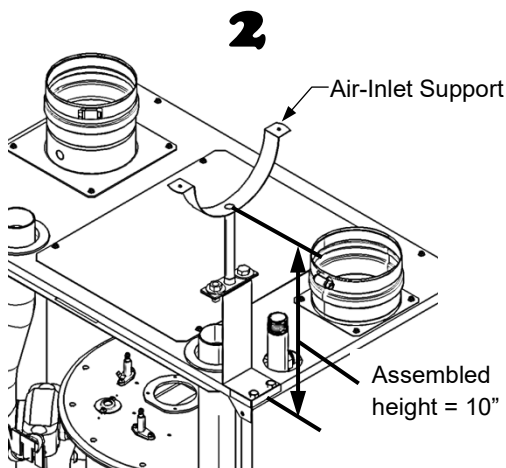

TFTN340-399

1. **Air-Inlet Supports (TFTN340-399)** – Remove the sheet metal screw from the front right corner of the cabinet then position the front mounting hole of the support bracket over the hole in the cabinet and reinstall the factory screw. Use a 1/4" x 3/4" Drill Point Screw to finish securing the support bracket. Repeat for each boiler.

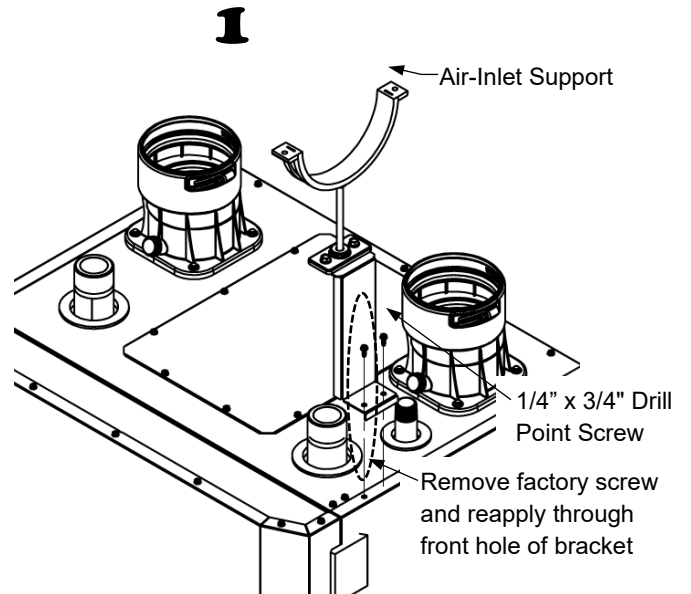

2. **Assembled Height (TFTN340-399)** – Ensure the assembled height of the Air-Inlet Supports measure 12" from the top of the boiler as shown; adjust as necessary.

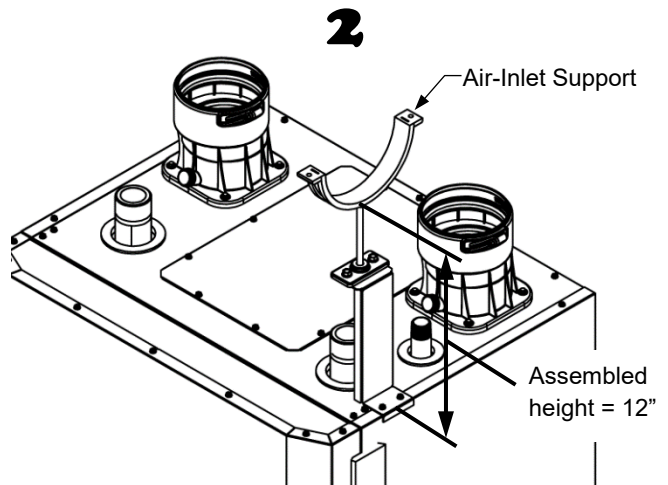

3. **Air-Inlet Appliance Adapter** – Insert the Air-Inlet Appliance Adapters into the Air-Inlet fittings of the boilers and tighten the gear clamps. Install the Elbows into the Air-Inlet Appliance Adapters and clip the Connector Rings. Angle the Elbows at 45° in the direction the Combustion Air-inlet is being piped (example is piped to the right).

NOTE: All Air-Inlet Appliance Adapter lengths are 9"; apply Centrocerin lubricant to each gasket and male end.

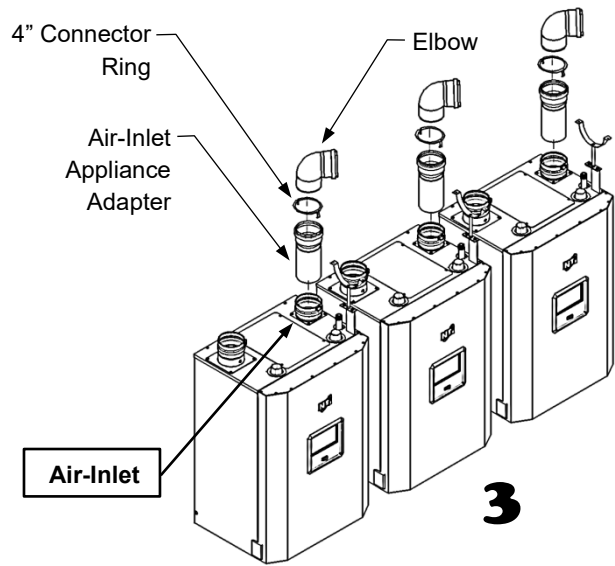

4. **Branch** – Insert the 6" x 4" Branch fittings into the 4" Elbows installed in Step 3, starting with the boiler on the left (start with the boiler on the right if the Combustion Air-inlet is being piped to the left). Use Centrocerin lubricant and a Connector Ring at each connection.

NOTE: Combustion Air-Inlet Branches are piped to the right; therefore, Branches are required to be cut to an overall length of 33"

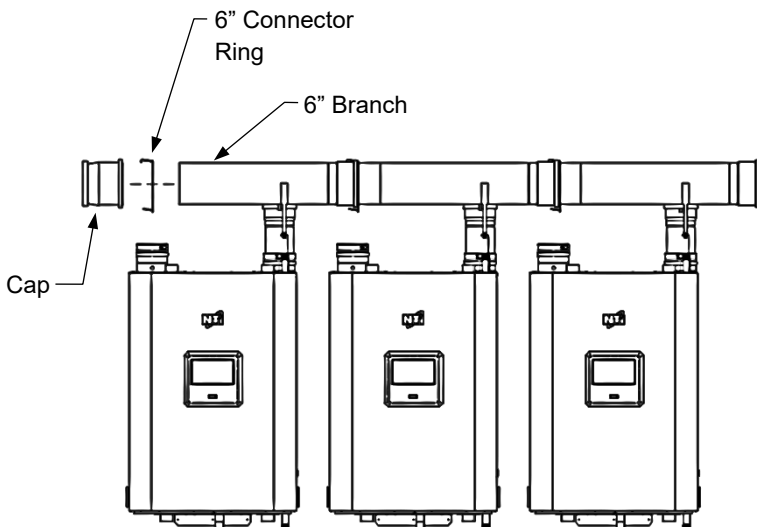
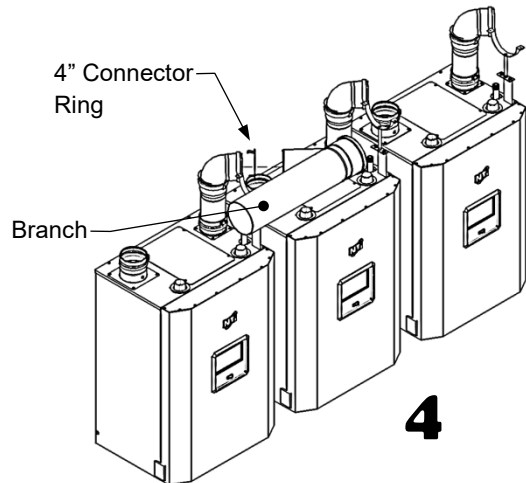

5. **Cap** – Install the Cap onto the left side (male end) of the Air-Inlet Manifold (if Combustion Air-inlet is being piped to the left, install Cap on the right side of the Manifold). Use Centrocerin lubricant and a Connector Ring at each connection.



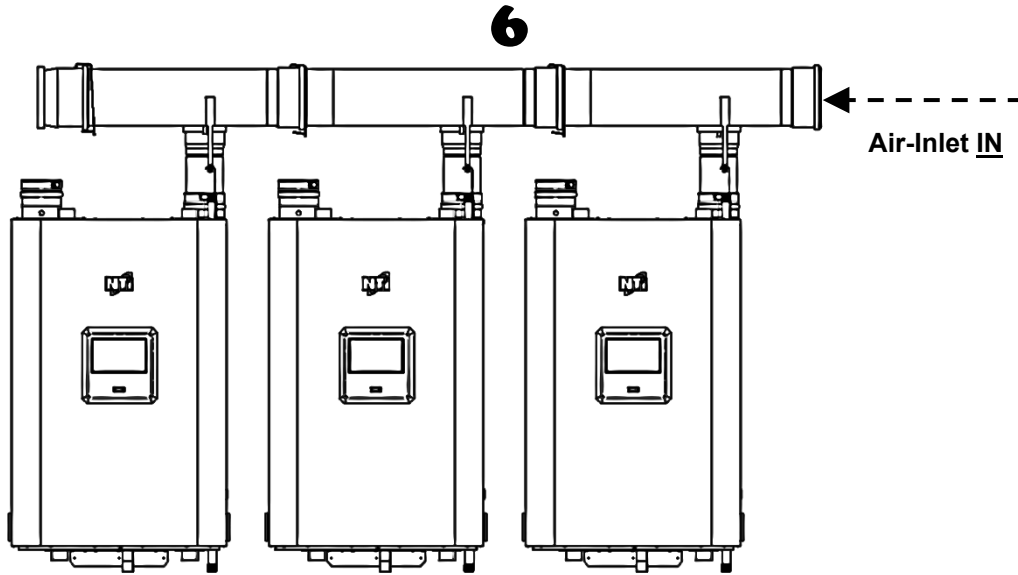

Exhaust Manifold Assembly Instructions (Steps 7 to 13)

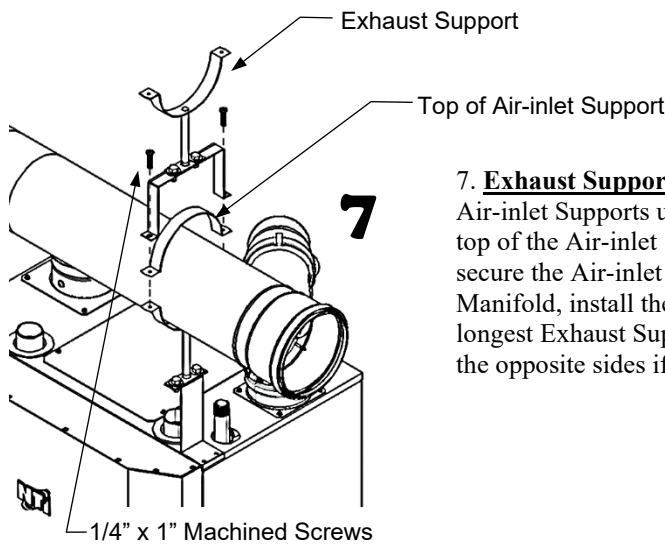

7. **Exhaust Support** – Fasten the Exhaust Supports to the top of the Air-inlet Supports using two 1/4" x 1" Machined Screws; sandwich the top of the Air-inlet Support in between the two, as illustrated, to secure the Air-inlet Manifold in place. To properly slope the Exhaust Manifold, install the shortest Exhaust Support on the left, and the longest Exhaust Support on the right (install shortest and longest on the opposite sides if the Exhaust Gas is being piped to the left).

8. **Exhaust Appliance Adapter** – To create a slope, the Exhaust Appliance Adapters are cut to different lengths. Connect the shortest adapter to the boiler on the left, and the longest adapter to the boiler on the right (install shortest and longest on the opposite sides if the Exhaust Gas is being piped to the left). Install a Non-Return Valve into each appliance adapter. Use Centrocerin lubricant and Connector Ring at each connection.

NOTE: Exhaust Appliance Adapter lengths:

- A = 11.0"
- B = 12.0"
- C = 13.0"

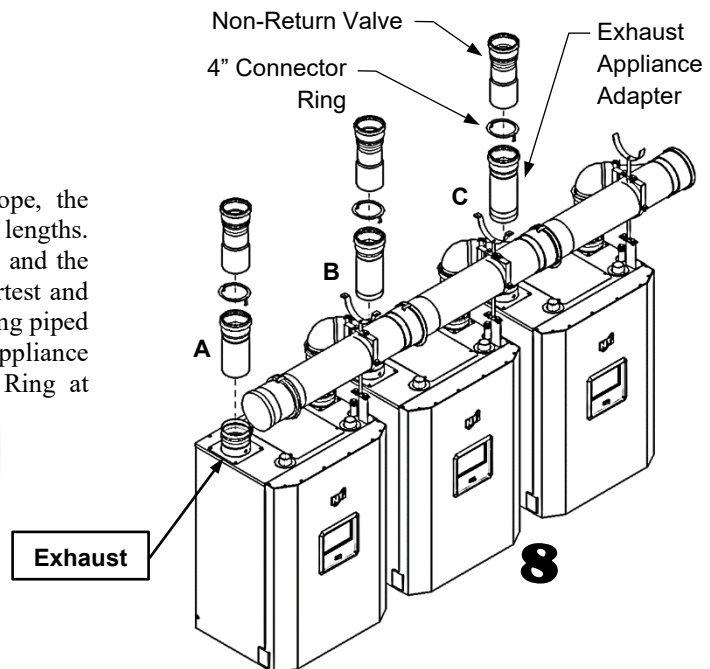

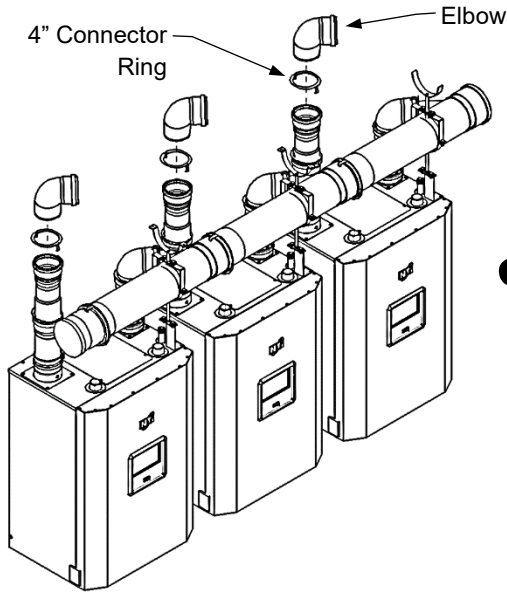

9

9. **Elbow** – Install the Elbows into the Non-Return Valves; angle the Elbows at 45° in the direction the Exhaust Gas is being piped (example is piped to the right).

Use Centrocerin lubricant and Connector Ring at each connection.



10. **Branch** – Insert the 6” x 4” Branch fittings into the 4” Elbows installed in Step 9, starting with the boiler on the left (start with the boiler on the right if the Exhaust Gas is being piped to the left). Use Centrocerin lubricant and a Connector Ring at each connection.

NOTE: Exhaust gas branches are piped to the right; therefore, Branches are required to be cut to an overall length of 33”

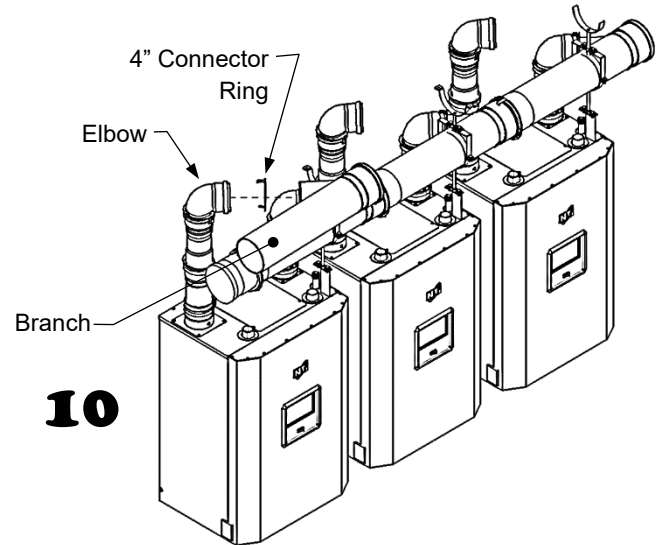

10

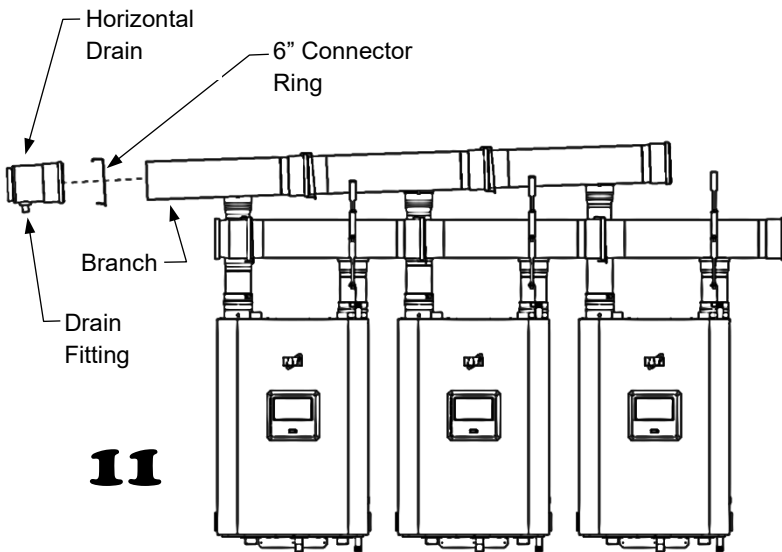

11

11. **Horizontal Drain** – Install the Horizontal Drain onto the left side (male end) of the Exhaust Manifold (if Exhaust Gas is being piped to the left, install Horizontal Drain on the right side of the Manifold). Use Centrocerin lubricant and a Connector Ring at each connection.



12. **Exhaust Support** – Secure the Exhaust Manifold in place by installing the tops of the Exhaust Supports using 1/4" x 1" Machine Screws.

Top of Exhaust Support
& 1/4" x 1" Machined
Screws

12

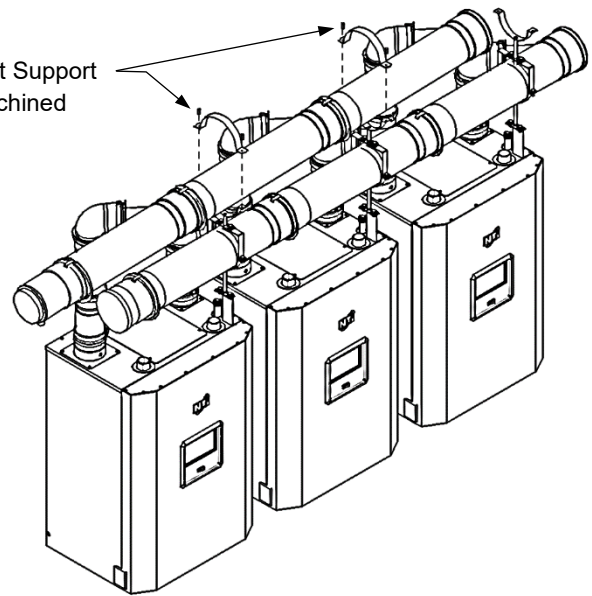

13

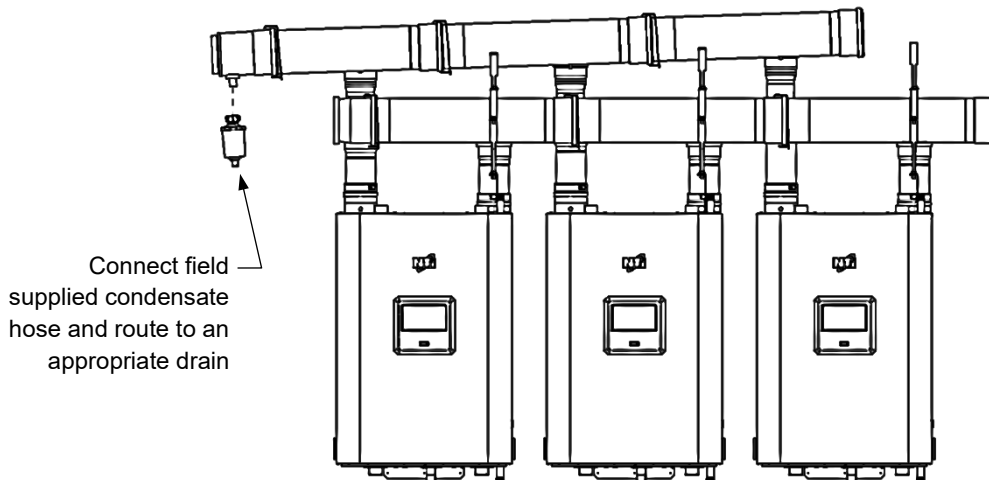

13. **Siphon** – Install the Siphon to the fitting of the Horizontal Drain. Connect a field supplied condensate hose and route to an appropriate drain.

Condensate Drain

NOTICE

Check with your municipality, or local gas company, to determine if the disposal of combustion condensate is permitted in your area (e.g., in the **State of Massachusetts** the condensate must be neutralized prior to entering a drain).

The following are important notes that must be taken into consideration when constructing the condensate drain system (See Condensate Drain section of the boiler Installation Manual for further details):

- **DO NOT** install condensate lines outside. A frozen or blocked drain will cause the condensate to back-up and leak. This may result in damage to boiler components resulting in a no heat condition; property damage may also occur.
- **NEVER** use copper, steel, or galvanized piping in the construction of the condensate system (condensate is very corrosive and will corrode most metals).
- When a condensate pump is used or required, select a pump that is designed for residential furnaces.

5.0 TERMINATION OPTIONS - DIRECT VENT

The Tft/TFTN Common Vent Manifold System is approved for **DIRECT VENT ONLY**. Installers are responsible for supplying the required Exhaust Gas and Combustion Air-inlet piping, termination components, Connector Rings and Support Clamps. Table 2-3 lists the Centrotherm – InnoFlue parts that are approved for terminating the Common Vent System.



WARNING

Terminations are to be **DIRECT VENT ONLY**. Failure to follow these instructions may result in property damage, serious injury or death.

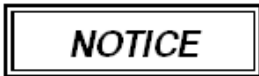

NOTICE

Refer to the boiler Installation and Operation Instructions, your local authority and the National Fuel Gas Code ANSI Z223.1 and or CAN/CGA B149 Installation Codes for termination clearance requirements.

Roof Termination

Figure 5-1 Roof Termination Example

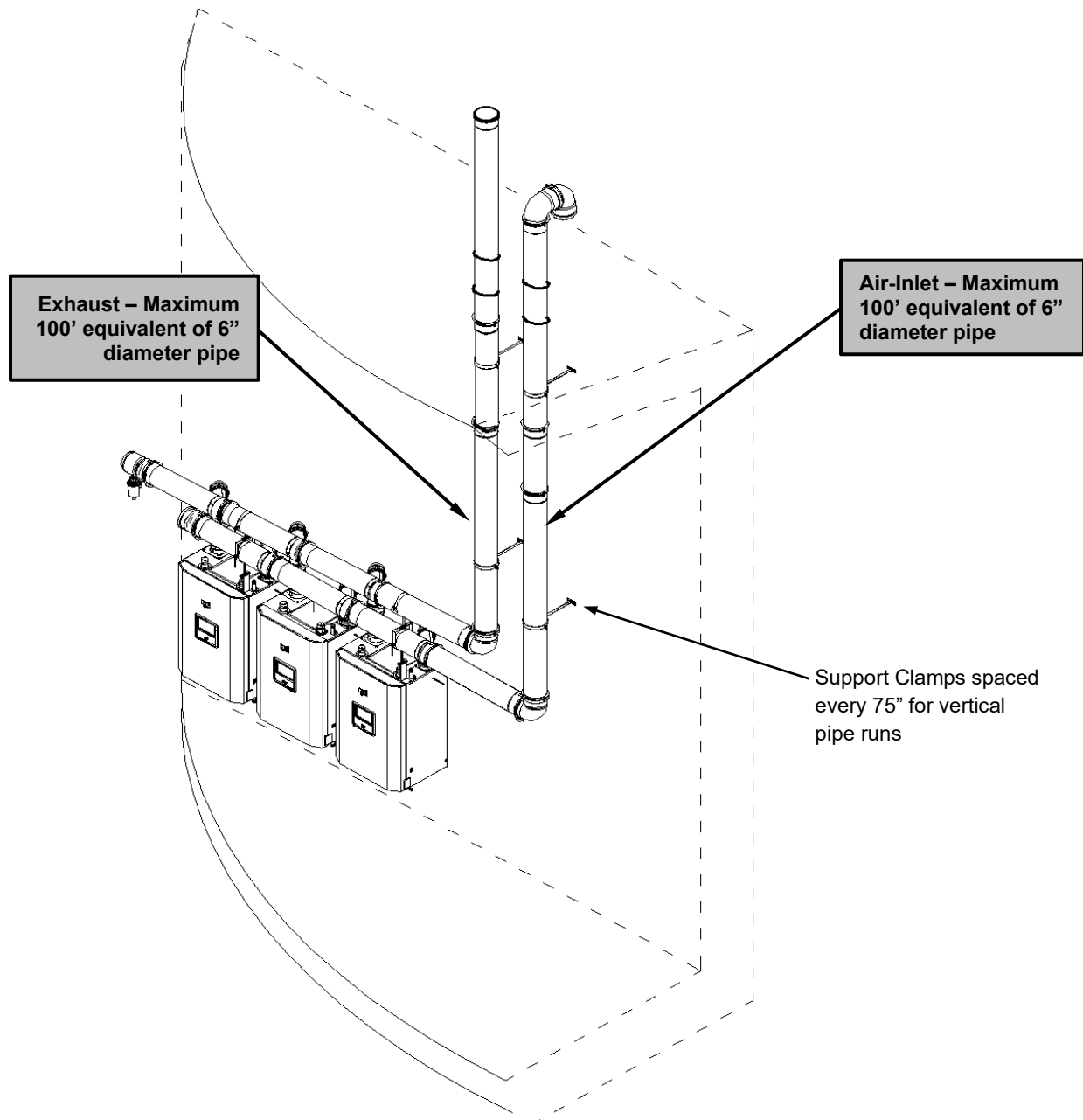

Roof Exhaust Sidewall Air-Inlet Termination

Figure 5-2 Roof Exhaust Sidewall Air-Inlet Termination Example

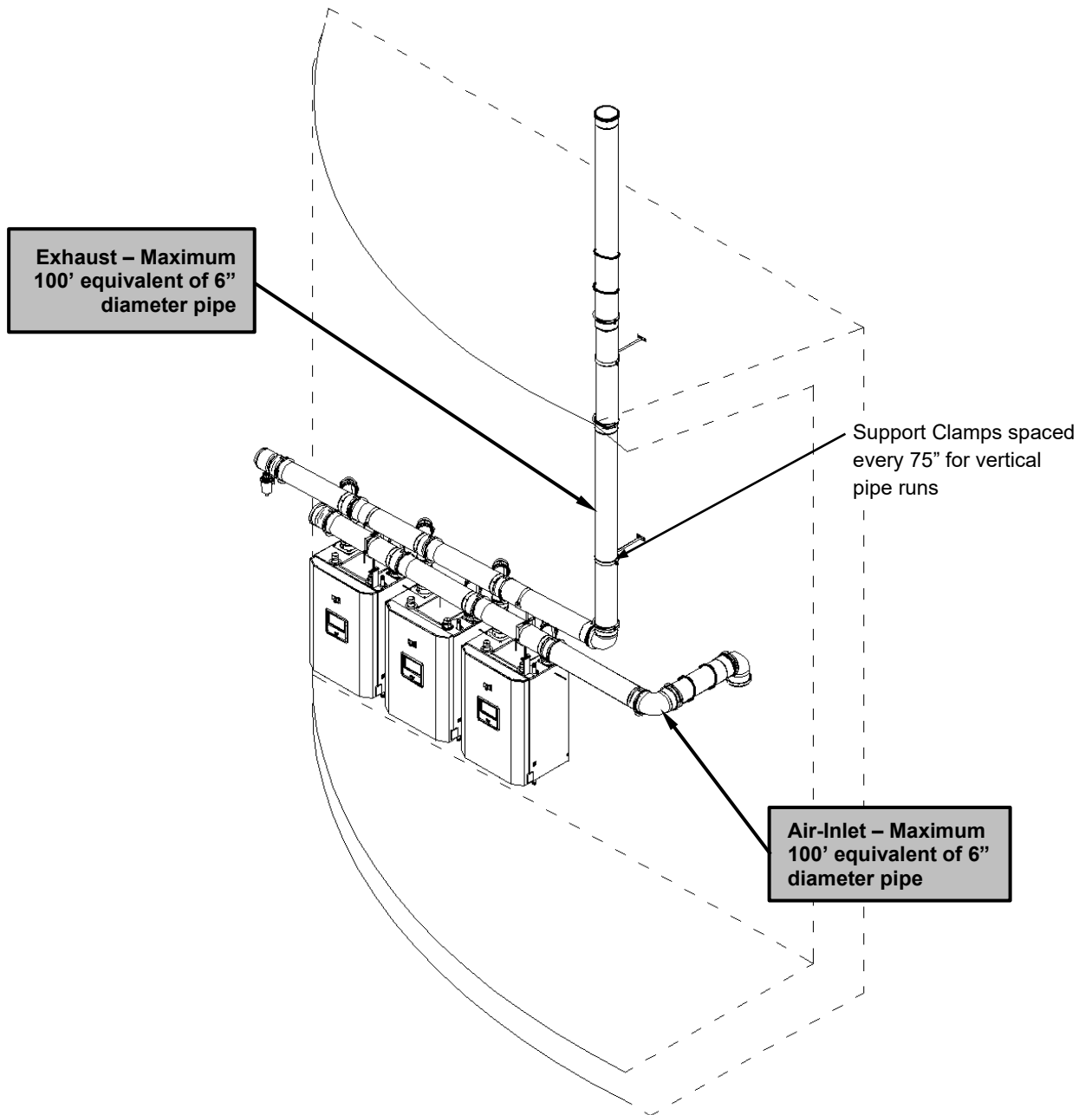
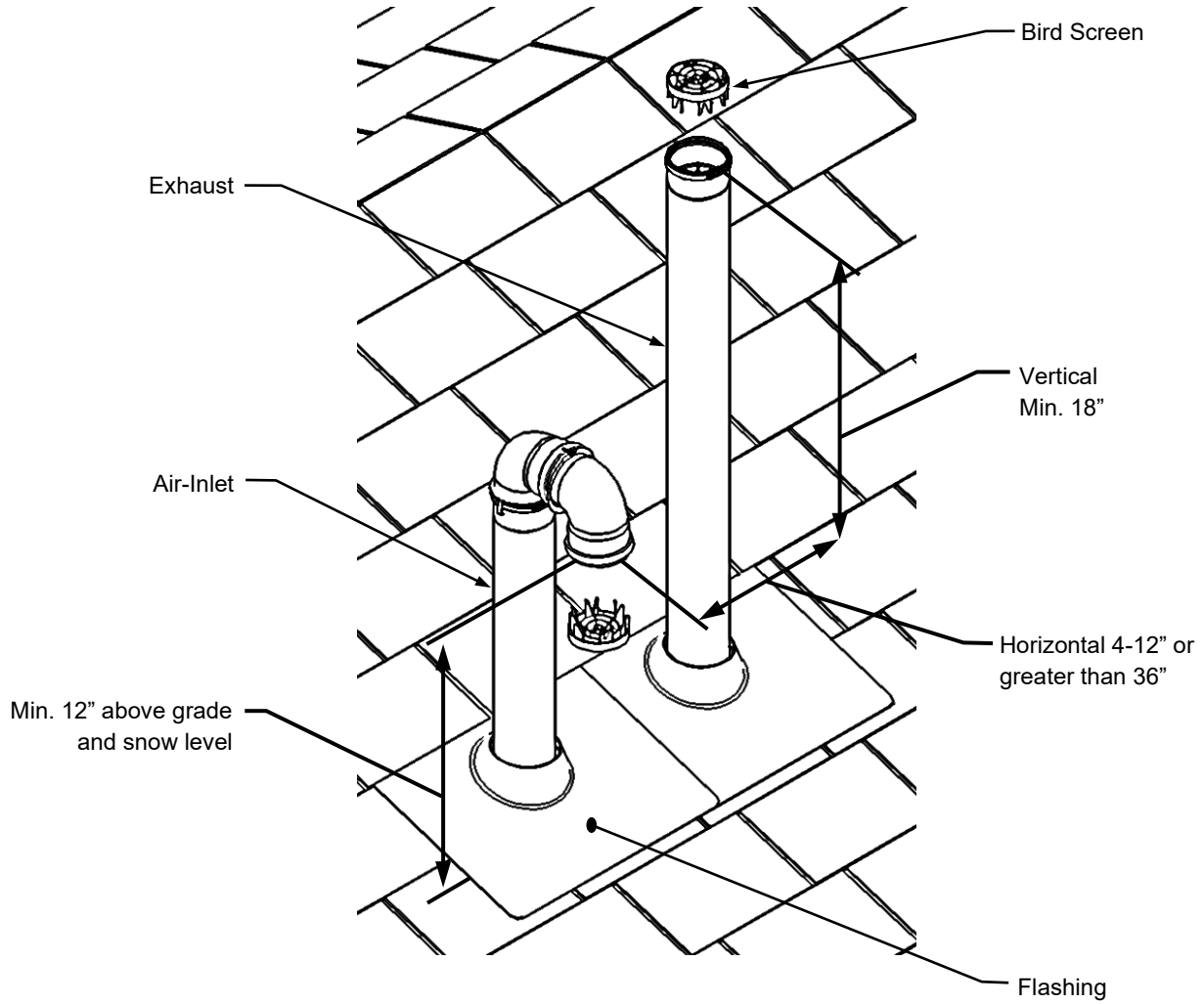

Figure 5-3 Roof Termination Details



WARNING

Refer to Centrotherm – InnoFlue documentation included with termination components for complete installation instructions.

Sidewall Termination

Figure 5-4 Sidewall Termination Example

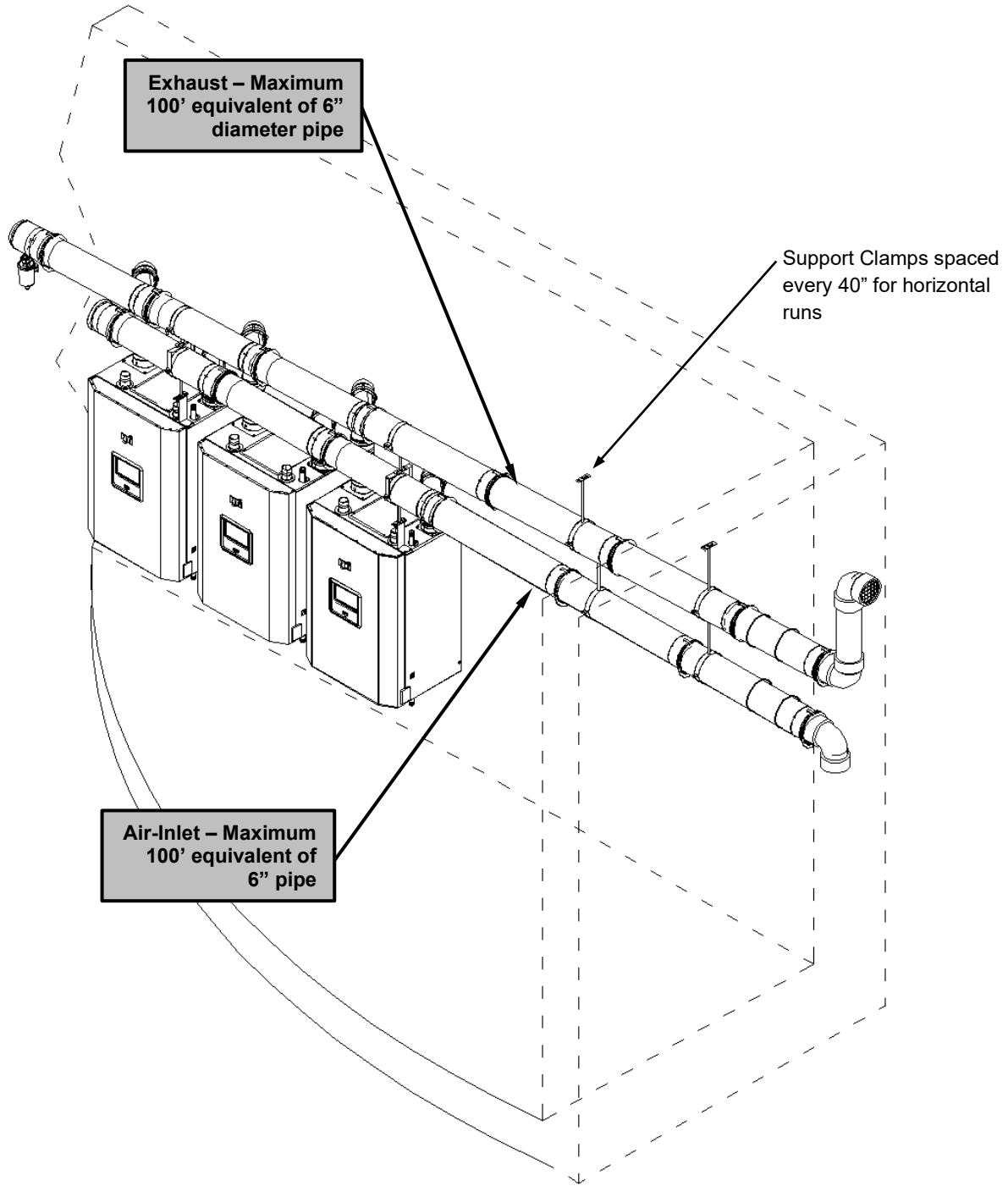
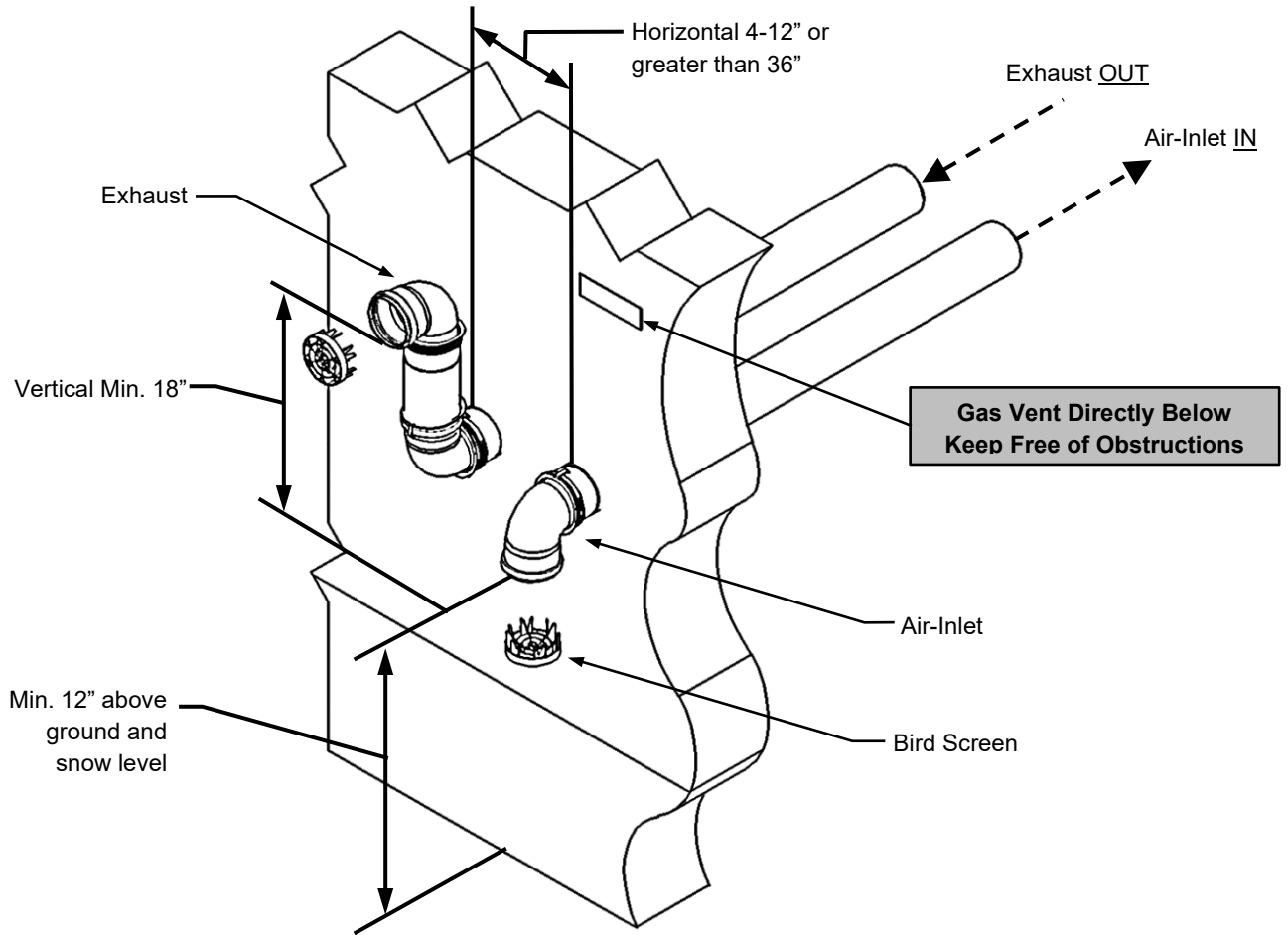

Figure 5-5 Sidewall Termination Details – Option 1



⚠ WARNING

Refer to Centrotherm – InnoFlue documentation included with termination components for complete installation instructions.

Figure 5-6 Sidewall Termination Details – Option 2

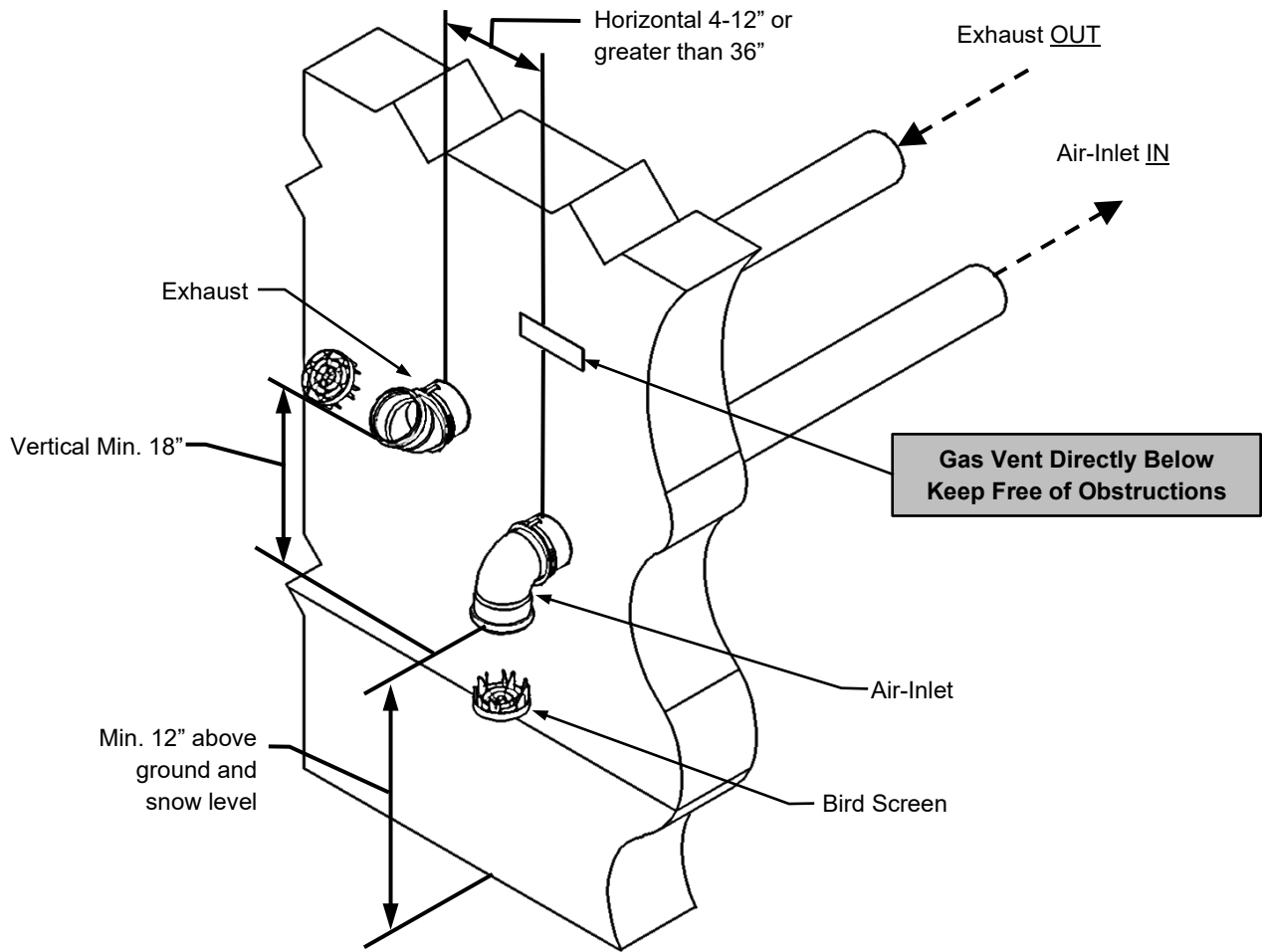

WARNING

Refer to Centrotherm – InnoFlue documentation included with termination components for complete installation instructions.

6.0 CHECKLIST

- 1. Read and understand this manual and the Installation and Operation Instructions provided with the Tft (NTI – P/N 99984535) and TFTN (NTI – P/N 99987137) Boilers. Understand the dangers associated with improper installation of the boilers, Common Vent Manifold System, common venting, and termination.
- 2. Perform the Installation Checklist from the boiler Installation and Operation Instructions.
- 3. Confirm that only Centrotherm – InnoFlue Polypropylene parts are used for the installation of this Common Vent System as outlined in Section 2.0 of this manual.
- 4. When wall mounting, confirm the boilers are exactly 5” apart from each other in accordance with Section 3.0 of this manual.
- 5. Install the Common Vent Manifold System in the order outlined in Section 4.0 of this manual.
- 6. Connector Rings are installed on every connection within the Common Vent Manifold, in accordance with Section 2.0 of this manual.
- 7. Support Clamps are installed on the Exhaust and Air-inlet piping every 75” on vertical runs and every 40” on horizontal runs in accordance with Section 2.0 of this manual.
- 8. Centrocerin lubricant was applied to each gasket and male end of every venting connection.
- 9. Termination of the Exhaust and Combustion Air-Inlet are in accordance with Section 5.0 of this manual.
- 10. Advise home/building owner of their responsibilities with respect to maintaining the boilers and Common Vent System.



WARNING Building owner is responsible for keeping the Exhaust Vent and Air-Inlet termination free of snow, ice, or other potential blockages and for scheduling boiler routine maintenance as described in the boiler installation instructions. Failure to properly maintain the boiler and Common Vent System may result in serious injury or death.

Operational Checklist

- 1. For each boiler perform the Operational Checklist in the boiler installation manual.
- 2. Ensure the Common Vent System is free of combustion leaks.
- 3. Confirm that each boiler ignites and operates smoothly (no delayed ignition and no pulsation).
- 4. Flue gas combustion readings are measured on each boiler and are within the tolerances indicated in the boiler installation instructions.
- 5. Condensate lines are properly secured, free of leaks and drain freely.
- 6. Ensure that each Non-Return Valve closes when the respective boiler is off.
- 7. Products of combustion are not detected at the flue outlet of inoperable boilers, while other boilers are running.

Before Leaving

- 1. Allow each boiler to complete at least one heating cycle or to operate for at least 15 minutes. At this point re-check the Common Vent System for combustion gas and condensate leaks.
- 2. Ensure the condensate traps are properly disposing the condensate in the appropriate location in accordance with Section 6.0 in the boiler installation instructions.

Instructions to Installing Contractor

- 1. Leave the manual with the customer so they know when to call for annual maintenance and inspection.

Annual Inspection Checklist

The Tft/TFTN – Common Vent System must be inspected at the beginning of every heating season by a Qualified Technician.

- 1. For each boiler perform the Annual Inspection Checklist in the boiler Installation and Operation Instructions.
- 2. Inspect the Common Vent System termination components for damages caused by exposure to weather elements. If termination components are damaged or worn have the parts removed and replaced.
- 3. Examine the termination Bird Screens for debris.
- 4. Examine all venting for evidence of leaks. If a leak is found repair or replace the part.
- 5. Look for condensate or debris in the Non-Return Valves, if found remove and clean them.
- 6. Examine the support clamps for rigidity; tighten if loose or replace if damaged.
- 7. Check the Connector Rings for a secure lock between each connection.
- 8. Conduct a visual inspection to ensure the Common Vent System is adequately sloped and not sagging.
- 9. Confirm there is nothing obstructing the flow of the Combustion Air-Inlet and Exhaust Gases.
- 10. Keep boiler area clear and free from combustible materials, gasoline, and other flammable vapors and liquids.



Failure to properly inspect each joint fitting in the Common Vent System may result in flue gas leakage causing serious injury or death.



NTI Boilers Inc. 30 Stonegate Drive, Saint John, NB E2H 0A4 Canada
Technical Assistance: 1-800-688-2575
Fax: 1-506-432-1135
www.ntiboilers.com