



# Trinity Lx800WH High Efficiency Gas-Fired Condensing Water Heater

## Submittal Sheet

Section 1 - Specifications  
Section 2 - Dimensions  
Section 3 - Electrical

Project Name: \_\_\_\_\_ Date: \_\_\_\_\_  
 Location: \_\_\_\_\_  
 Engineer: \_\_\_\_\_  
 Contractor: \_\_\_\_\_ Rep: \_\_\_\_\_

### 1 SPECIFICATIONS

#### General Specifications

- ▶ Product Features
  - Factory set to operate with Natural Gas (**NOTICE: not approved for use with Propane**)
  - Certified to ANSI Z21.10.3 / CSA 4.3 Gas Water Heater Standard
  - ASME "H" stamped boiler, designed and constructed in compliance with the ASME Boiler and Pressure Vessel Code Section IV
  - SA-249 TP316L Stainless Steel Heat Exchanger
  - CSD-1 compliant
  - Maximum operating pressure 160 psi [1103 kPa]
  - Modulating burner, 5:1 turndown
  - Direct Spark Ignition
  - Zero clearance to combustibles (clearances required for service)
  - Certified as Direct Vent (sealed combustion) or for use with indoor combustion air
- ▶ Optional Side Wall Vent Terminal Kits NTI part # 84355, 84358
- ▶ Optional Air Filter Kit NTI part # 84093 (indoor combustion air only)
- ▶ Factory Supplied Items
  - 10k thermistor System sensor
  - Flow switch
  - 150PSI ASME Relief Valve
  - 160PSI Pressure Gauge
- ▶ Control Features
  - Integral microprocessor safety control
  - Time of day input
  - Lead-Lag up to 8 Lx series water heaters
  - Integrated Modbus RTU for connection to BMS gateways

Water Connections NPT, in.	Gas Connection NPT, in.	Vent/Air-inlet Pipe Diameter, in.	Vent/Air-inlet Max. Length, ft.	Approx. Weight with Water, lb.
2 (Female)	1 (Male)	Air-inlet 4	100	475
		Vent 6	100	

#### Performance Specifications

Input Modulation, MBH	Gross Output Capacity, MBH	Thermal Efficiency, %	Recovery Rate @ 100°F Rise, USGPH
160 – 800	768	96	922

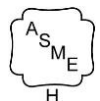
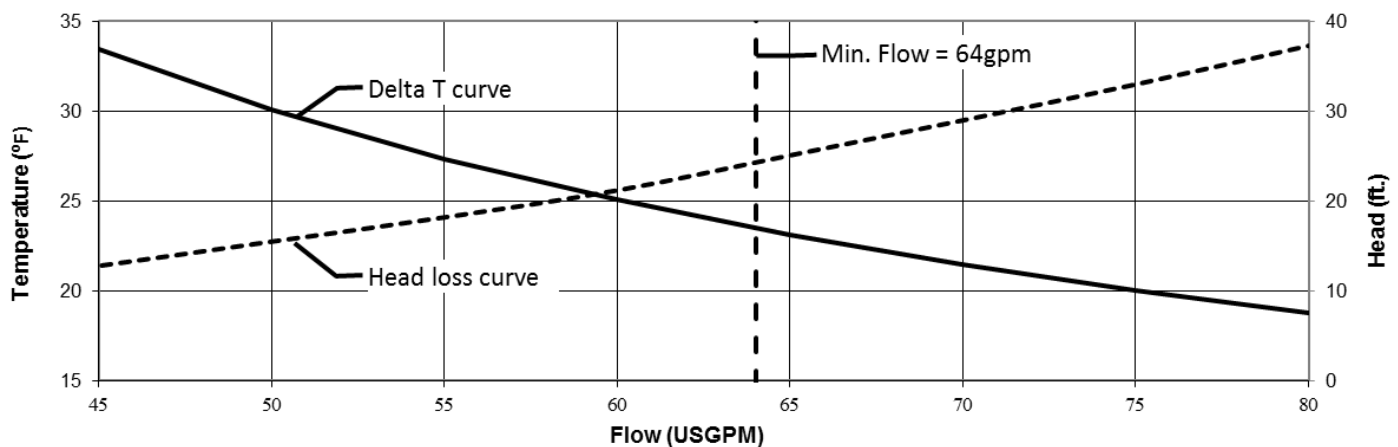



**Trinity Lx800WH  
High Efficiency Gas-Fired  
Condensing Water Heater**

**Submittal Sheet**

**2 DIMENSIONS**

**Product Dimensions – in. [mm]**

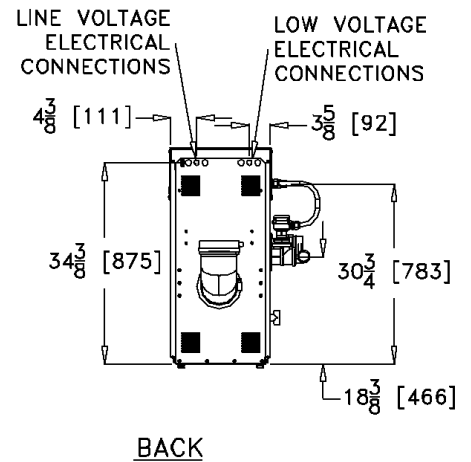
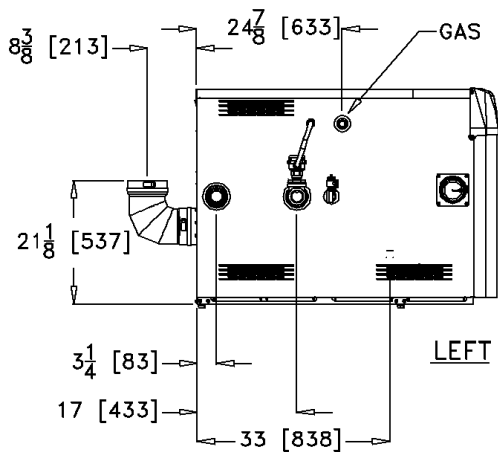
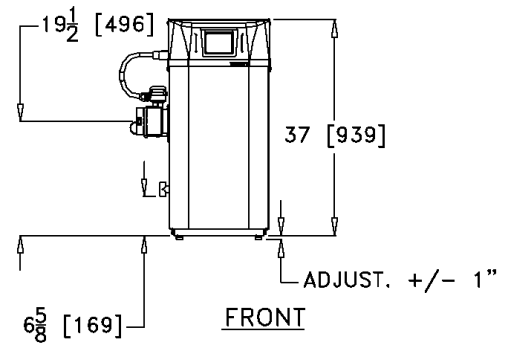
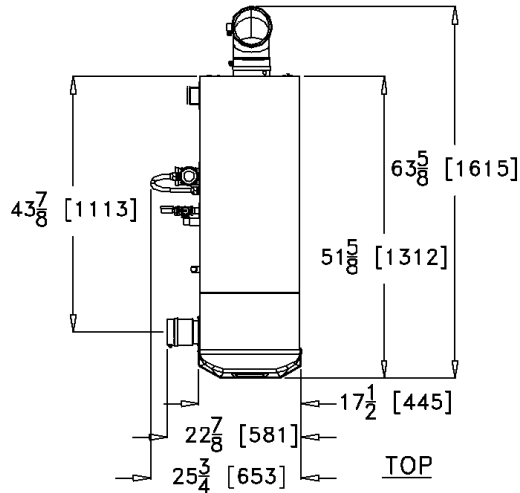

**Recommended Clearances – in. [mm]**

Top	Front	Left	Right	Back	Bottom
24 [610]	24 [610]	30 [762]	24 [610]	18 [457]	0

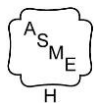



# Trinity Lx800WH High Efficiency Gas-Fired Condensing Water Heater

## Submittal Sheet

### 3 ELECTRICAL

#### Simplified Wiring Diagrams

##### Line Voltage Electrical:

- ▶ 120VAC / 60 Hz / 1 Phase / 12 Amp
- ▶ Barrier Strip for field wiring terminations
- ▶ 3 Pump outputs
  - Indirect Domestic Hot Water (Pump A)
  - Boiler (Pump B)
  - Central Heat (Pump C)

Note: Pumps are field supplied.

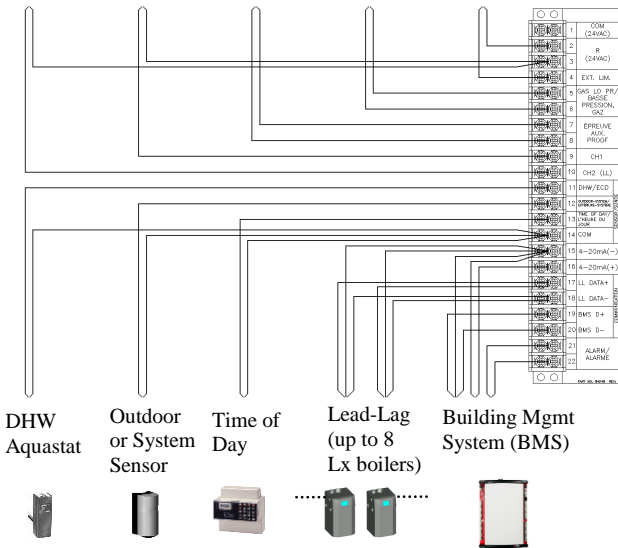
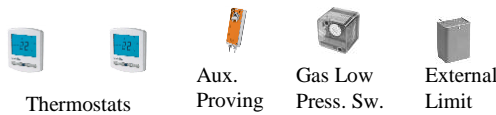
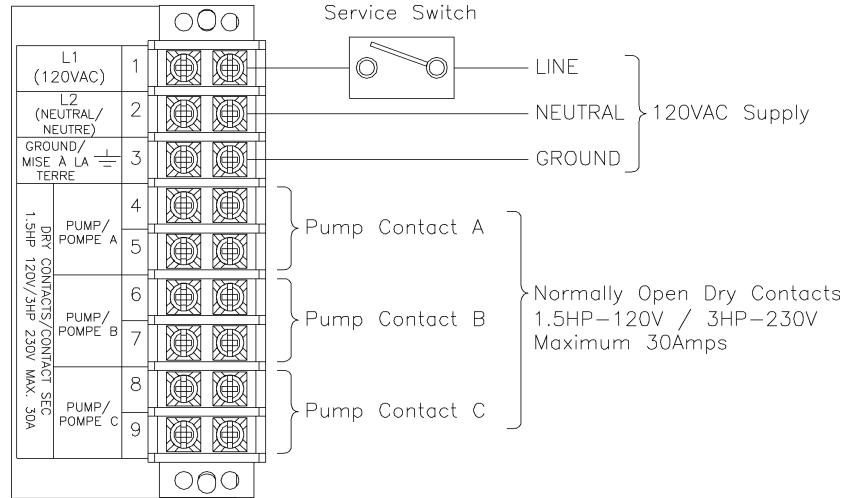

##### Low Voltage Electrical:

- ▶ Barrier Strip for field wiring terminations
- ▶ 120/24 VAC Transformer 40VA (factory supplied)
- ▶ Inputs
  - CH1 thermostat (by others)
  - CH2 thermostat (by others)
  - Indirect DHW aquastat (by others) or DHW Tank sensor (factory option)
  - External Limit (by others)
  - Outdoor sensor (factory supplied)
  - System sensor (factory option)
  - 4-20mA external modulating control (by others)
- ▶ Outputs
  - Alarm dry contact (24VAC 0.63A max.)
- ▶ EIA-485 Modbus communications for Lead-Lag
- ▶ EIA-485 Modbus to BMS gateways (not shown).  
Optional available gateways:
  - BACnet/N2- NTI part # 84946
  - LonWorks- NTI part # 84947

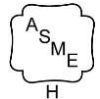

NTI Boilers Inc. 30 Stonegate Dr., Saint John, NB E2H 0A4 Canada