

"WF" Series Add-On Wood-Fired Boiler



WOOD-FIRED SERIES

After considerable research and testing, we are proud to produce the "WF" series of add-on wood-fired boilers. NTI wood-fired boilers are the most efficient, compact wood boilers on the market.

Consider the following comparisons and features:

- More compact sizes eliminate the need for floor reinforcement
- Greater heating surface
- Lower stack temperature
- No boiler tubes
- Less possibility of creosol buildup
- Thermostat heat control
- Wet leg, high-efficiency boiler design
- Designed to A.S.M.E. requirements
- Reduced standby losses due to thick insulation and low water mass
- Certified and rated to strict CSA codes
- The "WF" control system is developed to interact with the existing oil burner, automatically deactivating the burner when the "WF" wood boiler is in use
- Large fuel passages aid in cleaning and ensure that the accumulation of soot and creosote will not block flue passages

With its "WF" series of add-on wood-fired boilers, NTI continues to be the industry leader in reliability, efficiency and customer service.

With over 30 years of experience, NTI is acknowledged as a leader in boiler and furnace research and development – a pioneer in creating the most advanced and efficient home heating equipment. We won't bring a new product to you until it has passed the industry's most rigorous performance and quality testing.

You will enjoy years of trouble-free, comfortable, even heat from our "WF" series of add-on wood-fired boilers. Our customer service hotline and extended warranties maintain our commitment to you. Only from NTI.



DIM	WF200
A	42"
B	37"
C	13 1/2"
D	15 3/4"
E	8"
F	7"
G	7"
H	22 1/2"
I	30"
Combustion Area	18"h
	16"w
	25 1/2"d
Supply	1 1/2"
Ret	1 1/2"
RV	3/4"
Drain	1/2"
Sq. Ft. Ht. Surface	20
Weight	625 lbs.
Water Cap	43 Imp Gal.
BTU Capacity	95,000

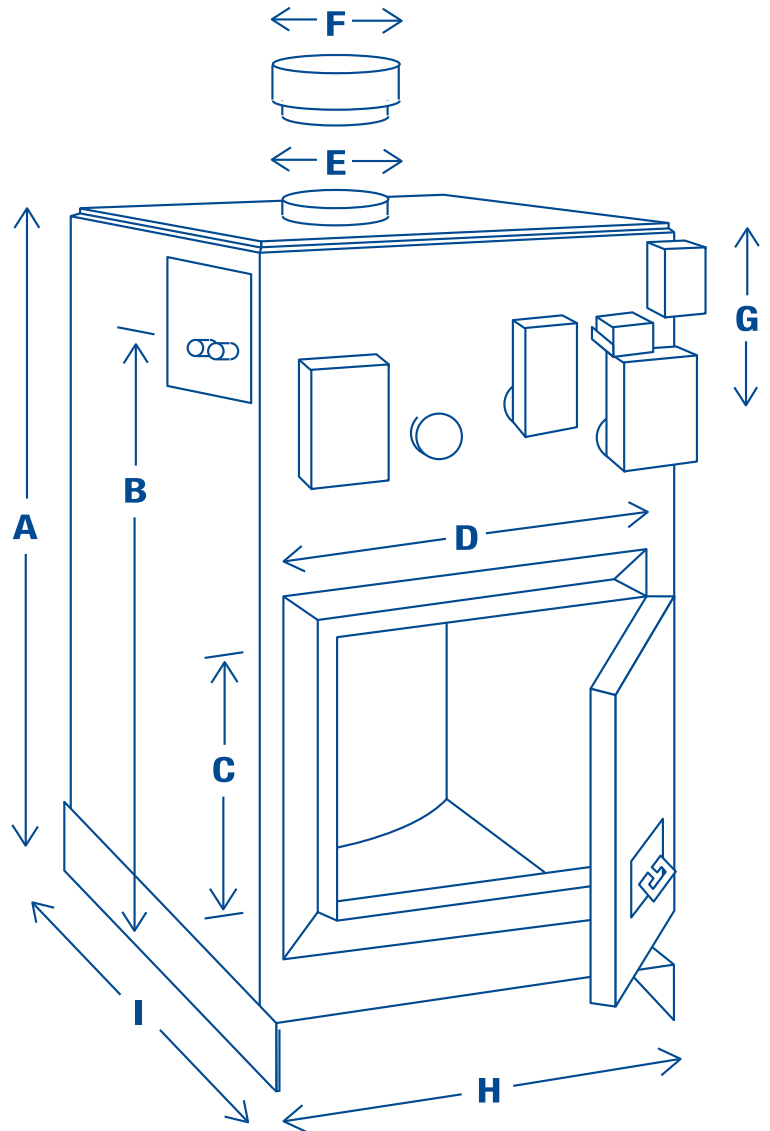

This boiler is supplied to automatically operate in conjunction with an oil boiler. Care must be taken to install and operate as a standalone appliance. Other controls are required for standalone operation.

Because we never stop improving the durability and performance of our quality line of products, we reserve the right to change specifications without prior notice.

For more information, please contact:



NY THERMAL INC.
30 Stonegate Drive
Saint John, New Brunswick
E2H 0A4 Canada
Tel: 506-657-6000
Toll-free: 800-688-2575
Fax: 506-432-1135

www.nythermal.com

The "WF" series of add-on wood-fired boilers has been the choice of consumers due to its economical operating cost and ease of servicing and cleaning. You may buy more expensive wood boilers, but you cannot buy better.

When you require the best, don't settle for anything less than NTI.

Distributor: